

eScholarship@UMassChan

Ethanol Sensitivity and Tolerance of Rat Neuronal BK Channels: A Dissertation

Item Type	Doctoral Dissertation
Authors	Wynne, Patricia M.
DOI	10.13028/8ped-8a27
Publisher	University of Massachusetts Medical School
Rights	Copyright is held by the author, with all rights reserved.
Download date	2026-03-14 12:15:38
Link to Item	https://hdl.handle.net/20.500.14038/31722

ETHANOL SENSITIVITY AND TOLERANCE OF RAT NEURONAL
BK CHANNELS

A Dissertation Presented

By

Patricia M. Wynne

Submitted to the Faculty of the
University of Massachusetts Graduate School of Biomedical Sciences, Worcester
in partial fulfillment of the requirements for the degree of

DOCTOR OF PHILOSOPHY

December 31, 2008

Neuroscience

ETHANOL SENSITIVITY AND TOLERANCE OF RAT NEURONAL
BK CHANNELS

A Dissertation Presented
By
Patricia M. Wynne

The signatures of the Dissertation Defense Committee signifies
completion and approval as to style and content of the Dissertation

Steven Treistman, Thesis Advisor

Jose Lemos, Member of Committee

Gyongyi Szabo, Member of Committee

Andrew Tapper, Member of Committee

Daniel Cox, Member of Committee

The signature of the Chair of the Committee signifies that the written dissertation meets
the requirements of the Dissertation Committee

Schahram Akbarian, Chair of Committee

The signature of the Dean of the Graduate School of Biomedical Sciences signifies that
the student has met all graduation requirements of the school.

Anthony Carruthers, Ph.D.,
Dean of the Graduate School of Biomedical Sciences

Neuroscience Program
December 31, 2008

ABSTRACT

BK channels are well studied targets of acute ethanol action. They play a prominent role in neuronal excitability and have been shown to play a significant role in behavioral ethanol tolerance in invertebrates. The focus of my work centers on the effects of alcohol on the BK channel and comprises studies that examine how subcellular location affects acute ethanol sensitivity and how duration of acute alcohol exposure impacts the development of rapid tolerance. My results also provide potential mechanisms which underlie acute sensitivity and rapid tolerance.

I first explore BK channel sensitivity to ethanol in the three compartments (dendrite, cell body, and nerve terminal) of magnocellular neurons in the rat hypothalamic-neurohypophysial (HNS) system. The HNS system provides a particularly powerful preparation in which to study the distribution and regional properties of ion channel proteins because the cell bodies are physically separated from the nerve terminals. Using electrophysiological and immunohistochemical techniques I characterize the BK channel in each of the three primary compartments and find that dendritic BK channels, similar to somatic channels, but in contrast to nerve terminal channels, are insensitive to alcohol. Furthermore, the gating kinetics, calcium sensitivity, and iberiotoxin sensitivity of channels in the dendrite are similar to somatic channels but sharply contrast terminal channels. The biophysical and pharmacological properties of

somatodendritic vs. nerve terminal channels are consistent with the characteristics of exogenously expressed $\alpha\beta1$ vs. $\alpha\beta4$ channels, respectively. Therefore, one possible explanation for my findings is a selective distribution of $\beta1$ subunits to the somatodendritic compartment and $\beta4$ subunits to the terminal compartment. This hypothesis is supported immunohistochemically by the appearance of distinct punctate $\beta1$ or $\beta4$ channel clusters in the membrane of somatodendritic or nerve terminal compartments, respectively. In conclusion, I found that alcohol sensitivity of BK channels within the HNS system is dependent on subcellular location and postulate that β -subunits modulate ethanol sensitivity of HNS BK channels.

In the second and primary focus of my thesis I explore tolerance development in the striatum, a brain region heavily implicated in addiction. Numerous studies have demonstrated that duration of drug exposure influences tolerance development and drug dependence. To further elucidate the mechanisms underlying behavioral tolerance I examined if BK channel tolerance was dependent on duration of alcohol exposure using patch clamp techniques in cultured striatal neurons from P8 rats. I found that persistence of rapid tolerance is indeed a function of exposure time and find it lasts surprisingly long. For example, after a 6 hr exposure to 20 mM ethanol, acute sensitivity was still suppressed at 24 hrs withdrawal. However, after a 1 or 3 hr exposure period, sensitivity had returned after only 4 hrs. I also found that during withdrawal from a 6 hr but not a 3 hr exposure the biophysical properties of BK channels change

and that this change is correlated with an increase in mRNA levels of the alcohol insensitive STREX splice variant. Furthermore, BK channel properties during withdrawal from a 6 hr exposure to alcohol closely parallel the properties of STREX channels exogenously expressed in HEK293 cells. In conclusion I have established that BK channels develop rapid tolerance in striatal neurons, that rapid tolerance is dependent upon exposure protocol, and is surprisingly persistent. These findings present another mechanism underlying BK channel tolerance and possibly behavioral tolerance. Since these phenomena are dependent on duration of drug exposure my results may find relevance in explaining how drinking patterns impact the development of alcohol dependence in humans.

TABLE OF CONTENTS

Title Page.....	i
Signature Page.....	ii
Abstract.....	iii
Table of Contents.....	vi
List of Tables.....	viii
List of Figures.....	viii
Introduction.....	1
Alcohol Addiction and Acquired Tolerance	1
Large Conductance Calcium-Activated Potassium Channels.....	2
Physiological Role of BK Channels.....	4
Methods to Examine the Properties of BK Channels	5
Pre-mRNA Splicing of BK α Subunits.....	7
Distribution of BK α Splice Site.....	9
Effects of Alcohol on Neuronal BK α Splice Site Variants.....	9
Additional Pharmacological Properties of Neuronal α Variants.....	12
Key Biophysical Properties of Neuronal BK α Splice Site Variants.....	13
Auxiliary BK β Subunits.....	15
Distribution of BK β Subunits.....	15
Effects of Alcohol on Neuronal BK β -Subunit Channels.....	16
Additional Pharmacological Properties of BK β -Subunit Channels.....	18
Key Biophysical Properties of BK β -Subunit Containing Channels.....	19

Properties of Various α Splice Variants Coexpressed with β Subunits.....	21
BK Channels in the Hypothalamic-Neurohypophysial System.....	21
The Mesolimbic-Dopaminergic Pathway.....	24
Chapter One.....	25
Abstract.....	27
Introduction.....	29
Materials and Methods.....	33
Results.....	39
Discussion.....	55
Acknowledgements.....	62
Chapter Two.....	63
Abstract.....	65
Introduction.....	67
Materials and Methods.....	70
Results.....	81
Discussion.....	114
Acknowledgements.....	121
Appendix A.....	122
Cumulative Discussion.....	127
Cumulative References.....	139

LIST OF TABLES

Chapter Two

Table 1	Summary of BK channel Properties in Striatal Culture vs. HEK293 cells.....	108
---------	--	-----

LIST OF FIGURES

Introduction

Figure 1	BK Channel Structure.....	3
Figure 2	Splice sites within the BK α protein structure.	8
Figure 3	Differential effects of EtOH on α splice variant activity.....	10
Figure 4	Alcohol affects on α splice variant mRNA levels.....	11
Figure 5	Cyclic AMP-dependent phosphorylation differentially regulates α splice variant activity.....	13
Figure 6	Differential calcium sensitivity of α splice variants.....	14
Figure 7	β -subunit modulation of alcohol sensitivity.....	16
Figure 8	β -subunit modulation of acute alcohol tolerance.....	17
Figure 9	β -subunit modulation of iberiotoxin sensitivity.....	18
Figure 10	β -subunit modulation of calcium sensitivity.....	20
Figure 11	Bright field image and schematic diagram of HNS system.....	23

Chapter One

Figure 1	Voltage and calcium dependence of HNS dendritic BK channels....	41
Figure 2	Conductance and calcium dependence of HNS BK channels.....	45

Figure 3	Gating properties of HNS BK channels.....	47
Figure 4	EtOH sensitivity of BK channels depends on subcellular location....	50
Figure 5	Subcellular distribution of β -subunits in the SON.....	53
Figure 6	BK β subunits in HNS nerve terminals.....	54

Chapter Two

Figure 1	Conductance, voltage dependence, and pharmacology of BK channels in cultured striatal neurons	83
Figure 2	Persistence of rapid tolerance is a function of EtOH duration.....	87
Figure 3	Dependence of G-V relationship on length of alcohol exposure....	91
Figure 4	BK gating properties depend on length of EtOH exposure.....	95
Figure 5	BK mean open and closed times depend on length of EtOH exposure.....	98
Figure 6	STREX mRNA levels depend on length of EtOH exposure.....	104
Figure 7	Biophysical properties of BK α splice variants.....	107
Figure 8	Effect of 8-Bromo-cAMP on striatal currents depend on EtOH exposure protocol.....	110
Figure 9	BK channel current density displays a complex recovery pattern during withdrawal dependent on length of EtOH exposure.....	113

Appendix A

Figure 1 Naïve striatal currents are Ibtx sensitive and develop acute tolerance.....	124
Figure 2 Immunolocalization of BK β 4 subunits in the HEK293 and striatal neurons.....	126

Cumulative Discussion

Figure 1 Mechanisms Underlying BK Channel Tolerance.....	138
--	-----

INTRODUCTION

Alcohol Addiction and Acquired Tolerance

Alcohol addiction is a major socioeconomic and public health concern affecting millions of people worldwide. Acquired tolerance has long been implicated as one of the defining characteristics of alcohol dependence by either permitting or causing increased levels of alcohol consumption (Kalant, 1998). Acquired functional tolerance refers to the physiological neuroadaptations that decrease the sensitivity of the central nervous system to the effects of alcohol. These physiological neuroadaptations are the result of a complex interaction of pharmacological, environmental, and behavioral factors (Suwaki et al., 2001; Bitran and Kalant, 1991). The mechanisms underlying these neuroadaptations are fundamental to our understanding of addiction.

There are multiple classes of tolerance that develop depending on the duration and pattern of exposure to the drug (Kalant, 1998). Behaviorally, tolerance can be classified as acute, rapid, or chronic. Acute tolerance refers to a decrease in impairment within a single session of alcohol exposure on the descending limb of the blood alcohol level (BAL) curve when the same BAL on the ascending limb produces noticeable impairment (LeBlanc et al., 1975). Rapid tolerance, on the other hand, refers to a reduced response to a second dose of alcohol administered 8-24 hrs after a first dose of alcohol (Bitran and Kalant, 1991). Lastly, chronic tolerance describes reduced effects of alcohol after multiple

drinking sessions. Tolerance to drugs can be produced by several different mechanisms and many studies have sought to identify the cellular targets underlying behavioral tolerance. Here, we focus on large conductance calcium-activated potassium (BK) channels because of their well known role in shaping action potentials and their well documented responsiveness to acute alcohol (Dopico et al., 1999a; Dopico et al., 1998; Dopico et al., 1996) Feinberg-Zadek, 2007, 2008; (Benhassine and Berger, 2008; Matthews et al., 2008).

Large Conductance Calcium-Activated Potassium Channels

Large conductance calcium-activated potassium (BK) channels are activated both by membrane depolarization and intracellular calcium levels. They are characterized by their large conductance, >200 pS, and selectivity for potassium. BK channels are comprised of 4 α subunits translated from a single gene KCNMA1 or *Slo*. The gene name *Slo*, short for *Slowpoke*, was derived from the lethargic phenotype observed when BK currents were eliminated in the flight muscles of *Drosophila melanogaster* (Elkins et al., 1986).

Each α subunit has seven transmembrane domains, S0-S6, which form the pore of the channel and a large C-terminal tail, S7-S10 (Figure 1). Each of these domains have specialized functions. The S0 domain allows the α subunit to associate with auxiliary β subunits (Wallner et al., 1996). The S2-S4 segment of the α subunit contains a series of arginine residues which comprise the voltage

sensor while the distal portion of the C-terminal tail contains the calcium bowl and two regions called regulators of conductance of K⁺ domain (RCK) (Bao et al., 2004; Bao et al., 2002). The RCK domains contain multiple sites selective for calcium and other divalent cations such as magnesium. Interestingly, the large C-terminal tail exceeds the length of the membrane-spanning domains, a feature unique to channels within the *Slo* family (Salkoff et al., 2006).

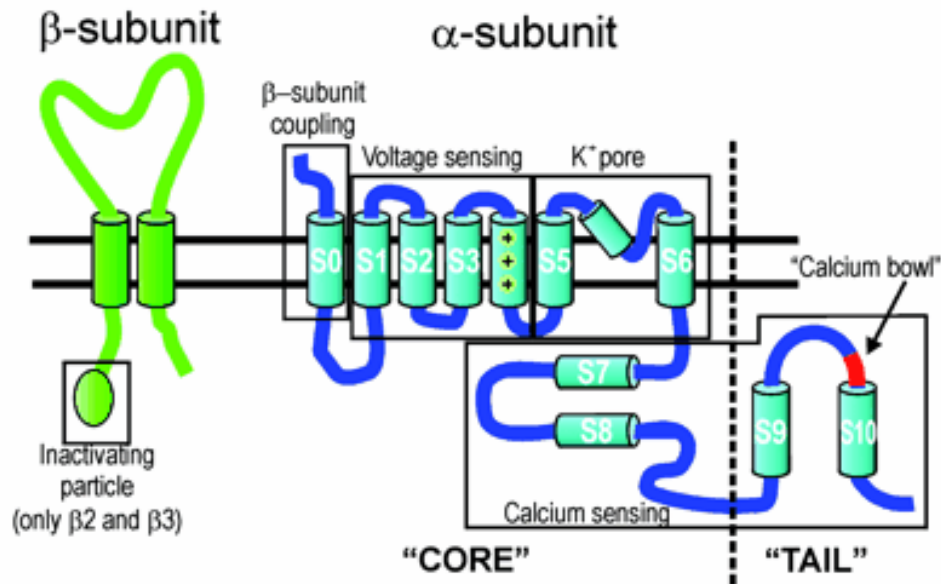

Figure 1. Schematic of BK channel structure. Seven transmembrane domains, S0-S6, form the pore of the channel. The functions of the domains are indicated with black boxes. The C-terminal tail containing S7-S10 contain the calcium sensing regions of the BK channel. An auxiliary β subunit containing two transmembrane domains is shown in green. Of the four β subunits only $\beta 2$ and $\beta 3$ have an inactivating particle. Adapted from Orio et al., 2002.

Physiological Role of BK Channels

Large conductance calcium activated potassium (BK) channels play a prominent role in cellular excitability from repolarizing neuronal action potentials to modulating contractility in vasculature (Liu et al., 2004; Fernandez-Fernandez et al., 2004; Toro et al., 1998). They are found ubiquitously throughout the brain and are highly conserved in mammals (Toro et al., 1998). BK channels are activated by both cell membrane depolarization and increases in intracellular calcium (Ghatta et al., 2006), allowing them to integrate intracellular calcium levels and membrane voltage. The importance of BK channel regulation including its expression and biophysical properties has been highlighted in numerous studies. Underscoring the role of BK channels in neuronal excitability, missense mutations of the *Slo* gene in humans causes generalized epilepsy (Du et al., 2005). Similarly, knockout of the auxiliary BK- β 4 subunit in mice also causes an epileptic phenotype (Brenner et al., 2005). Illustrating their ubiquitous role throughout the body, mouse *Slo* knockout strains exhibit a variety of abnormal phenotypes including ataxia, hearing loss, vascular hypertension, overactive bladder function and erectile dysfunction (Sausbier et al., 2004; Ruttiger et al., 2004; Sausbier et al., 2005; Thorneloe et al., 2005; Werner et al., 2005; Brown et al., 2008).

Methods to Examine the Biophysical Properties of BK Channels

Ion channels are often studied by measuring the ion flow or current through the channel pore (Hamill et al., 1981). This is done using a variety of patch clamp techniques which involve forming a high resistance gigaohm seal between the lipid membrane of a cell and a heat polished glass pipette. This seal allows one to record the activity of the channel. Three patch clamp techniques are utilized to measure the current flow through single channels.

The first technique is cell-attached patch clamp, in which you record channel activity directly after forming a gigaohm seal with the cellular membrane. This allows one to record the activity of channels in the patch of membrane at the tip of the pipette while keeping the intracellular environment of the cell intact. This technique is particularly useful to determine the effects of drugs without disrupting the cell.

The second technique is called inside-out patch clamp. To perform this technique after the gigaohm seal is formed, the recording pipette is lifted away from the cell, ripping off the patch. In this scenario, the lipid membrane containing the channel or channels remains at the tip of the pipette with any associated proteins, like phosphatases or kinases, and channel activity subsequently recorded (Franciolini, 1986). The inside-out patch derives its name from the fact that when the patch is ripped off the intracellular surface of the

channel is exposed to the outside. With respect to BK channels this technique allows one to assess, for example, the calcium sensitivity of the channel by perfusing the intracellular side of the channel (where the calcium sensing domains reside) with a series of solutions containing different calcium concentrations.

The third technique is called outside-out patch clamp. In this technique, after the seal is formed the patch is ruptured by applying negative pressure through the pipette, usually by aspiration. After rupturing the patch the pipette is excised from the cell. The lipid membrane reforms at the tip of the pipette such that the extracellular or outside surface of the ion channel is exposed to the outside of the pipette. Again with respect to BK channels this technique is particularly useful to assess the effects of channel blockers, for example, which are known to bind to the extracellular side of the channel.

While the techniques I've described above are useful to examine single channel currents there are also methods to examine the current flowing through an entire population of channels called the macroscopic current. Macroscopic currents are recorded using conventional whole-cell patch clamp. This technique is performed by rupturing the patch of membrane under the pipette (as in outside-out patch clamp) after the gigaohm seal is formed. This provides electrical

continuity between the pipette and the inside of the cell thereby allowing one to measure the current flowing through an entire population of channels.

Using a combination of the aforementioned techniques the properties of BK channels, including calcium and voltage sensitivity, gating kinetics, and pharmacological attributes such as alcohol sensitivity, have been shown to vary significantly between tissues, neighboring cells, and even subcellular compartments. From exogenous expression studies we now know that these physiological differences are partially due to two post-transcriptional mechanisms; (1) pre-mRNA splicing of the α subunit and (2) functional association with regulatory β subunits.

Pre-mRNA Splicing of BK α Subunits

The α subunit can undergo significant pre-mRNA splicing to yield a diverse complement of BK channel isoforms that differ in their functional properties, tissue distribution, and regulation by intracellular signaling cascades. The majority of alternative α splice sites reside in the large C-terminal tail (Figure 2)(Xia et al., 2002; Krishnamoorthy et al., 2005). Of these isoforms STREX, short for stress axis hormone-regulated exon, and Insertless, also called ZERO have been the most extensively studied. The STREX variant contains a 59 amino acid insert at the X4 splice site. This amino acid insert contains an additional protein kinase A (PKA) phosphorylation site (designated (P) in the figure below) which

has been shown to alter the channels response to PKA activators (Tian et al., 2001). Insertless, on the other hand, lacks an insertion at the X4 splice site (Xie and McCobb, 1998). Recently, P27 also called ALCOREX has been identified which contains a 27 amino acid insert at the X6 splice site (Ha et al., 2000). P27 was coined the name ALCOREX because of its extreme sensitivity to alcohol (Pietrzykowski et al., 2008).

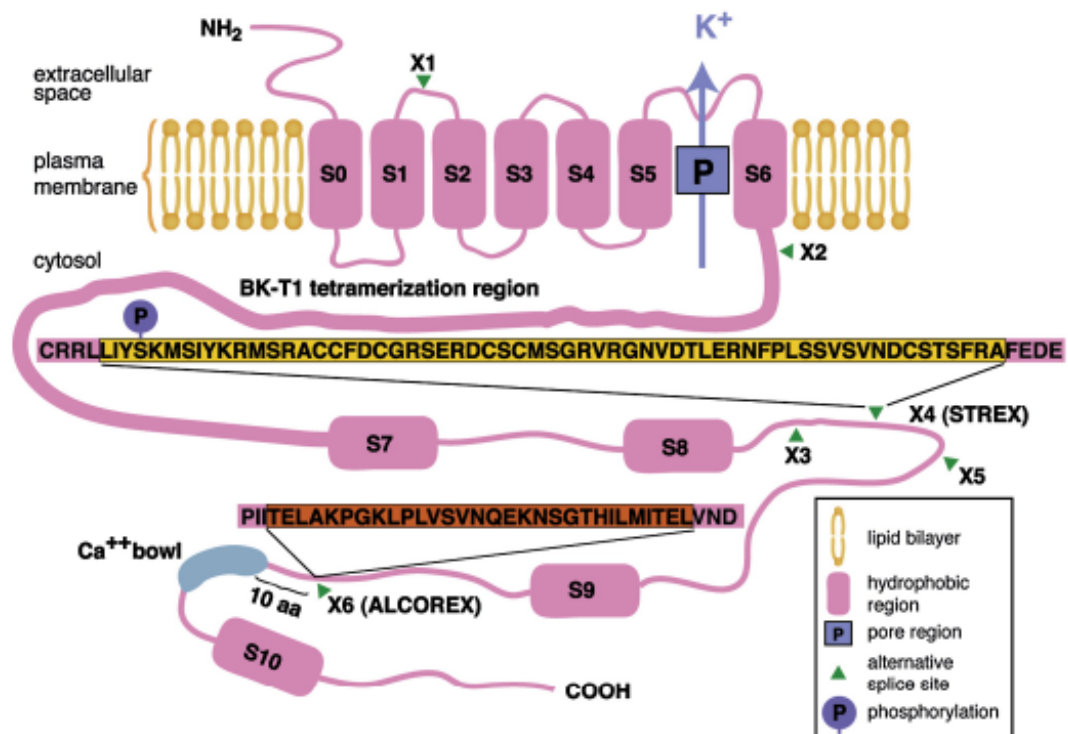

Figure 2. Schematic diagram of splice sites within the BK α protein structure. Splice sites are designated X1-X6. Adapted from Pietrzykowski et al., 2008.

Distribution of BK α Splice Site Variants

BK α mRNA is expressed in almost every tissue except heart atrium, ventricle, and septum (Behrens et al., 2000). BK channels in native tissues display a physiologically diverse array of phenotypes. To date, three isoforms have been described in neuronal tissues, Insertless, STREX, and P27 (Saito et al., 1997; Xie and McCobb, 1998; Ha et al., 2000; Pietrzykowski et al., 2008). In mouse brain the Insertless isoform, also referred to as ZERO, is the predominant variant, accounting for more than 90% of total BK mRNA while the remaining 10% is comprised mostly of STREX mRNA (Chen et al., 2005). Additionally, in situ hybridization experiments performed on sections of mouse brain reveal STREX mRNA is detected in adult neurons particularly in the hippocampus, cerebellum, and olfactory bulb (Petrik and Brenner, 2007). Furthermore, RT-PCR experiments reveal P27 mRNA in the hippocampus, cortex, cerebellum, mid brain, and brain stem (Ha et al., 2000).

Effects of Alcohol on Neuronal BK α Splice Site Variants

Slo variants are differentially sensitive to alcohol. The majority of *slo* channels are dose dependently activated by alcohol. The exceptions include bovine *slo* which is inhibited by alcohol (Liu et al., 2006) and STREX which is insensitive to ethanol (Figure 3A). Furthermore, our lab has also shown that between the ethanol sensitive variants, Insertless and P27 (ALCOREX), the degree of alcohol-induced potentiation can vary (Figure 3B). Additionally, splice

site variation appears to modulate the rate at which acute alcohol tolerance develops. Acute alcohol tolerance refers to a reduced effect of a drug within a single exposure to ethanol. With respect to BK channels, acute tolerance means a reduction in alcohol-induced potentiation within a single dose of ethanol. In the figure below, in the presence of 50 mM EtOH channel activity of the Insertless isoform increases, however, after 6 minutes of alcohol exposure channel activity returns to baseline. P27 (ALCOREX), on the other hand, takes 10 minutes to return to baseline (Figure 3B).

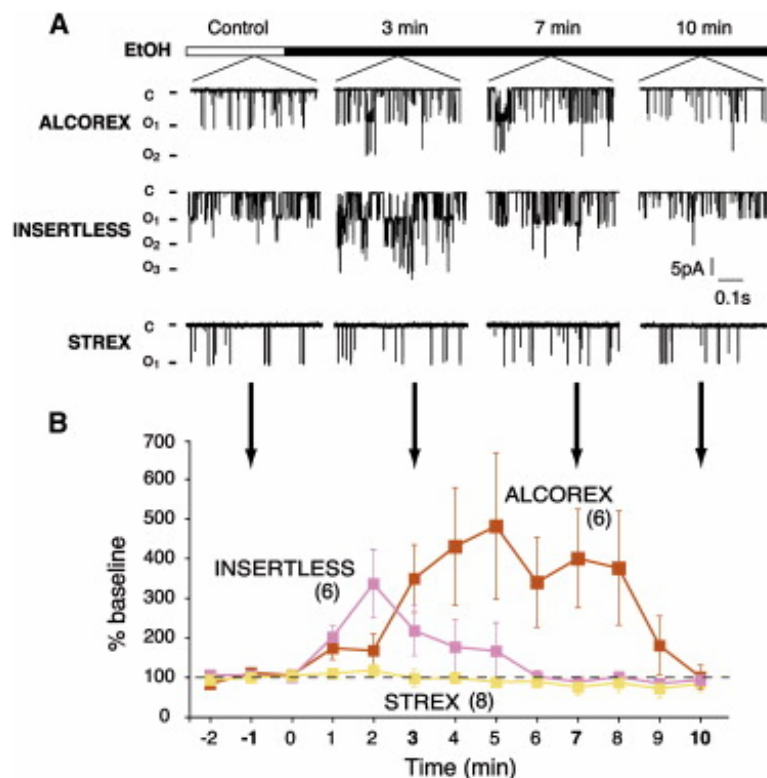

Figure 3. Differential response of α splice variants to acute ethanol exposure. (A) Single channel currents recorded in inside-out patch clamp mode in the presence of 5 μ M-free Ca²⁺ before and after exposure to 50 mM EtOH.

Splice site variants were exogenously expressed in HEK293 cells. (B) Plot of the percent change in baseline activity in response to alcohol exposure beginning at time 0. Adapted from Pietrzykowski et al., 2008.

Moreover, our lab has also discovered that α splice variant transcripts are differentially regulated in response to alcohol. We found that within the rat hypothalamic-neurohypophysial system (discussed later in the introduction) STREX mRNA relative to total BK mRNA increases in response to alcohol while the proportion of P27 mRNA diminishes (Figure 4).

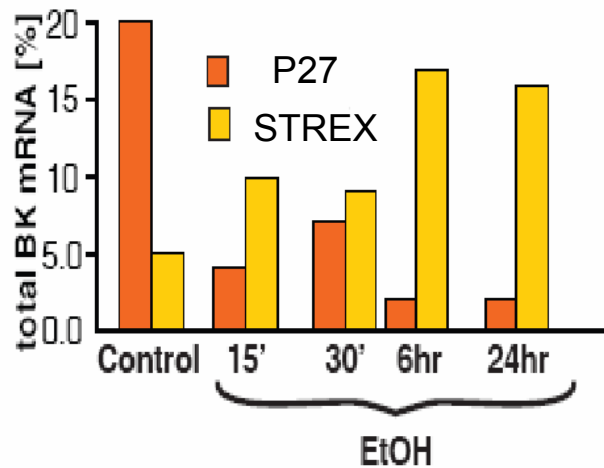

Figure 4. Alcohol affects the relative proportion of specific α splice variants to total BK mRNA. RT-PCR data of P27 and STREX splice variant mRNA levels in response to 20 mM EtOH in adult supraoptic neurons of the rat. Figure adapted from Pietrzykowski et al., 2008.

Additional Pharmacological Properties of Neuronal BK α Splice Variants

Slo channels are also differentially modulated by secondary signaling pathways. Many studies have shown that *Slo* channels are modulated by PKA, PKG, PKC, serine/threonine kinases, and CAMKII (Reinhart et al., 1991; Wang et al., 1999b; Zhou et al., 2001; Zhou et al., 2002; Jin et al., 2002; Chen et al., 2005; Liu et al., 2006). Of these kinases, PKA modulation of *Slo* channels has been the most extensively studied. It is well documented that BK channels containing even one STREX subunit per tetrameric assembly are inhibited by cyclic AMP-dependent phosphorylation. In contrast, Insertless and two other non-neuronal variants (e20 and e22) are potentiated by cyclic AMP-dependent phosphorylation providing a useful experimental tool to distinguish between splice variants (Figure 5) (Tian et al., 2001; Chen et al., 2005).

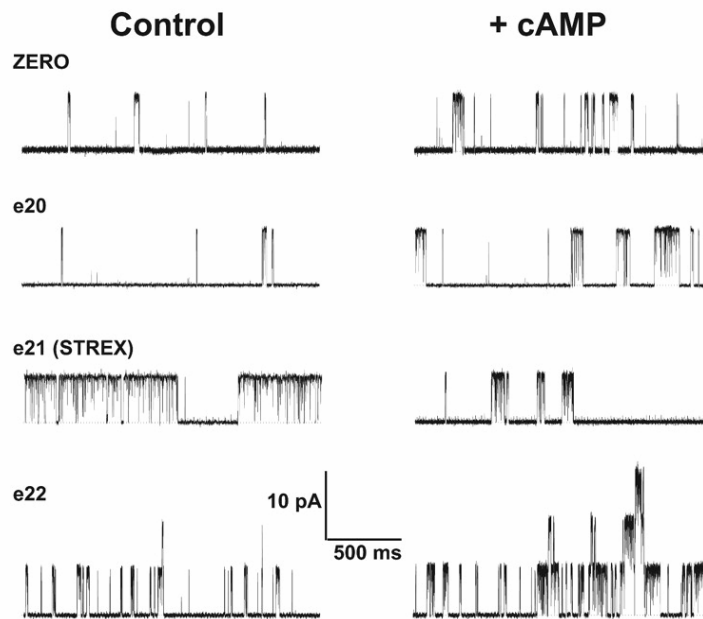

Figure 5. Differential regulation of BK channel activity by cyclic AMP-dependent phosphorylation. Channel activity is recorded in the inside-out patch clamp mode at +40 mV in the presence of 0.2 μM free- Ca^{2+} before and after exposure to 0.1 mM cAMP. Murine splice variants were expressed in HEK293 cells. Adapted from Chen et al., 2005.

Key Biophysical Properties of Neuronal BK α Splice Variants

Neuronal splice variants display a range of biophysical properties including changes in calcium sensitivity and kinetics. A common way to measure the calcium sensitivity of BK channel current is to determine the voltage where one-half the maximal conductance is observed ($V_{1/2}$). An increase in sensitivity is

reflected as a shift in $V_{1/2}$ to more negative or hyperpolarized values. Conversely, a decrease in calcium sensitivity is reflected as a shift in $V_{1/2}$ to more positive or depolarized potentials. In this way it was shown that STREX channels are more sensitive to calcium than Insertless (ZERO) channels (Figure 6) (Xie and McCobb, 1998). STREX channels also display slower rates of deactivation than Insertless channels (Chen et al., 2005). Due to these properties, the STREX exon enhances BK channel openings relative to Insertless channels (Saito et al., 1997; Xie and McCobb, 1998). In contrast to the marked differences in calcium sensitivity and deactivation, the voltage dependence and single channel conductance of both Insertless and STREX channels are similar (Chen et al., 2005; Petrik and Brenner, 2007). P27 BK channel currents have not been described in great detail however it has been shown that P27 currents activate more rapidly than channels lacking the 27 amino acid insert and this difference is dependent on calcium concentration (Ha et al., 2000).

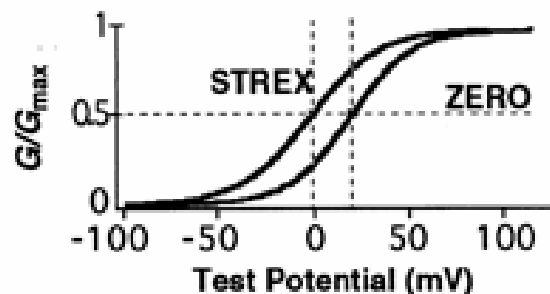

Figure 6. Differential calcium sensitivity of α splice variants. G/G_{\max} curves were generated from macroscopic currents recorded from macro-patches in

inside-out patch clamp mode from a holding potential of -100 mV to +100 mV in the presence of 10 μM free- Ca^{2+} . Splice variants were expressed in *Xenopus* oocytes. Figure adapted from Xie and McCobb, 1998.

Auxiliary BK β Subunits

Another source of functional diversity within BK channels depends upon the association of α subunits with auxiliary transmembrane β subunits. β subunits are glycosylated proteins that form non-covalent bonds (Garcia-Calvo et al., 1994; Knaus et al., 1994) with the α subunit. Currently four β subunits, β 1-4, have been identified from 4 different genes, KCNMB1-4.

Distribution of BK β Subunits

β subunit expression has been shown to be relatively tissue specific. Several studies indicate that human β 1 (h β 1) subunits are primarily localized in smooth muscle tissue, hair cells, and some neurons (Knaus et al., 1994; Giangiacomo et al., 1995; Jiang et al., 1999; Wanner et al., 1999). H β 2 subunit expression is especially abundant in the ovaries but is only weakly detected in several other tissues, including the brain (Wallner et al., 1999; Brenner et al., 2000). Similarly, H β 3 shows the highest expression in the pancreas and testis with weak expression detected in the brain (Brenner et al., 2000). In contrast to the other β subunits, β 4 is highly expressed in the brain and only weakly detected in other tissues (Brenner et al., 2000).

Effects of Alcohol on Neuronal BK β -Subunit Containing Channels

β -subunits differentially modulate the channels sensitivity to alcohol. Acute challenge with physiologically relevant alcohol doses as low as 25 mM EtOH potentiate the activity of α or $\alpha\beta_4$ channels expressed in HEK293 cells (Feinberg-Zadek and Treistman, 2007). In contrast, the baseline activity of $\alpha\beta_1$ channels remains unchanged throughout acute ethanol exposure indicating these channels are insensitive to the drug (Figure 7)(Feinberg-Zadek et al., 2008).

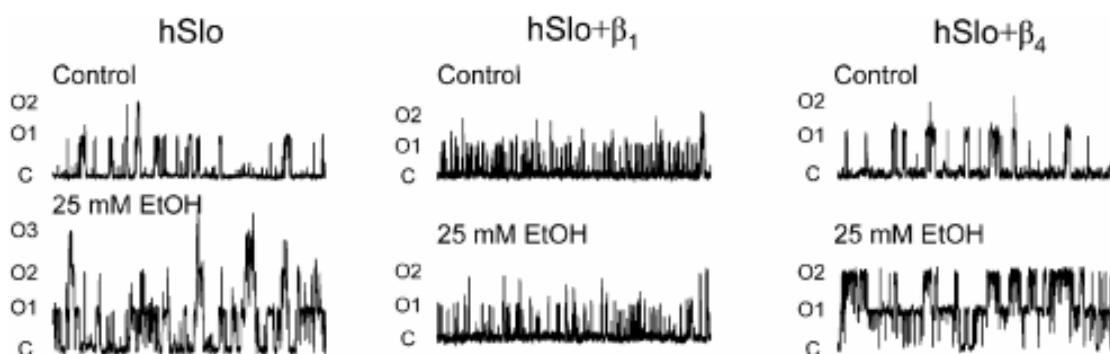

Figure 7. β subunit modulation of alcohol sensitivity. BK channel activity recorded in inside-out patch clamp mode in the presence of 1 μ M-free Ca^{2+} before and after 2 min of perfusion with 25 mM EtOH. Adapted from Feinberg-Zadek et al., 2008.

In addition to acute sensitivity β subunits also modulate the development of acute alcohol tolerance. Recently our lab has discovered that α Insertless channels develop acute tolerance while $\alpha\beta_4$ channels do not. Using HEK293 cells expressing either α or $\alpha\beta_4$ channels we demonstrated that both channel types

are acutely potentiated by 50 mM EtOH within a couple of minutes. However, after 7 minutes of EtOH application, only α channel activity returns to baseline. In contrast, when the neuronal auxiliary $\beta 4$ subunit is coexpressed with the α subunit, channel activity in response to alcohol remains elevated and does not develop acute tolerance (NPo after 3 min alcohol is 0.41 and remains potentiated at 8 min, NPo = 0.38) (Figure 8) (Martin et al., 2008).

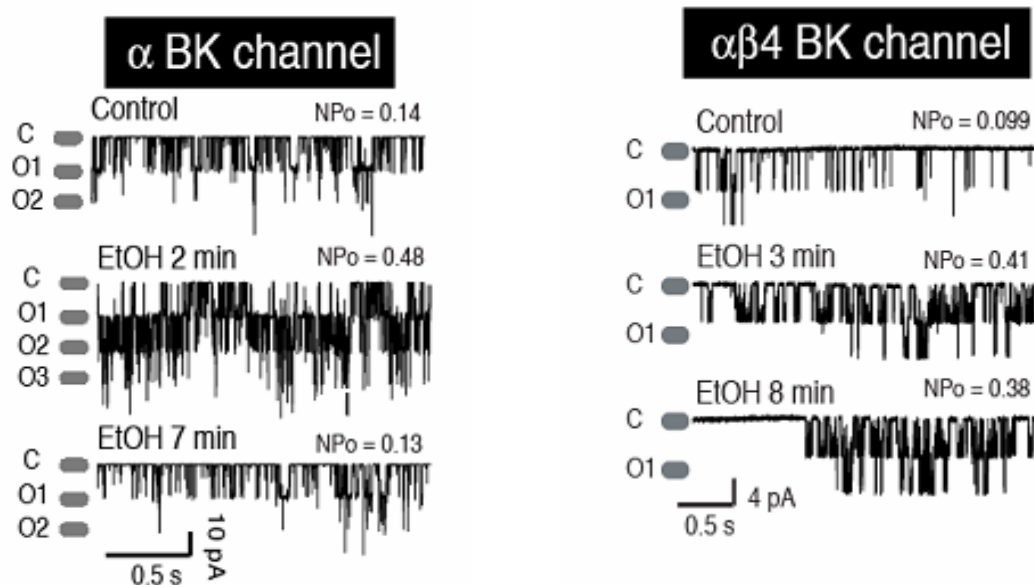

Figure 8. β -subunit modulation of acute alcohol tolerance. Effect of 50 mM EtOH on α and $\alpha\beta 4$ BK channels expressed in HEK293 cells. Single channels were recorded in cell-attached patch clamp mode for 20 sec every minute up to 20 min. C and O reflect the closed and open state respectively. Adapted from Martin et al., 2008.

Additional Pharmacological Properties of Neuronal BK β -Subunit Containing Channels

Another useful tool to distinguish between β subunits is their sensitivity to channel blockers. Iberitoxin and charybdotoxin are two BK channel blockers that were isolated from scorpion venom and bind to the external vestibule of the channel to block the pore (MacKinnon and Miller, 1988; Naini et al., 1996). Typically, both α and $\alpha\beta 1$ channels are blocked by bath application of either 100 nM iberitoxin (IbTX) or charybotoxin (ChTX). The $\beta 4$ subunit, on the other hand, uniquely confers resistance to these peptide blockers by slowing toxin association with the pore (Figure 9)(Behrens et al., 2000; Meera et al., 2000; Lippiat et al., 2003).

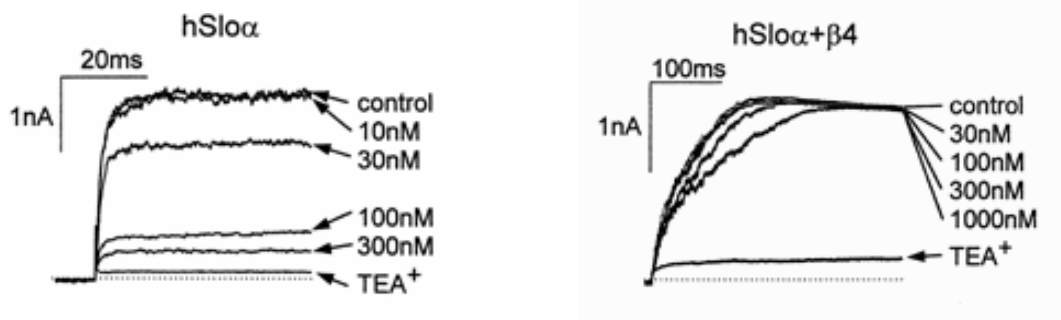

Figure 9. β -subunit modulation of iberitoxin sensitivity. Response of hSlo α or hSlo $\alpha\beta 4$ macroscopic currents to various concentrations of iberitoxin. Macroscopic currents were recorded from outside-out macro patches in the presence of 10 μ M free-Ca²⁺ before and after perfusion with iberitoxin or 10 mM TEA. Channel constructs were expressed in HEK293 cells. Adapted from Lippiat et al., 2003.

Key Biophysical Properties of Neuronal BK β -Containing Channels

In addition to conferring differential sensitivity to pharmacological agents like alcohol and iberiotoxin, association with auxiliary β subunits has been shown to modulate the calcium sensitivity, activation kinetics, and gating kinetics (mean open and closed times) of BK channels. Utilizing the same measure of calcium sensitivity described above Brenner et al. in 2000 discovered that coexpression of α Insectless with the β 1 subunit in oocytes increased the calcium sensitivity of the channel such that the midpoints of the conductance/voltage relationship ($V_{1/2}$) are shifted to more hyperpolarized values relative to α alone (no β) (Figure 10). Interestingly, the β 4 subunit has a much steeper calcium dependence than the other $\alpha\beta$ subunit combinations showing decreased calcium sensitivity in low intracellular calcium concentrations and increased calcium sensitivity in higher calcium concentrations. During that same year similar results were obtained with α , $\alpha\beta$ 1, and $\alpha\beta$ 4 channels expressed in HEK293 and CHO cells (Behrens et al., 2000).

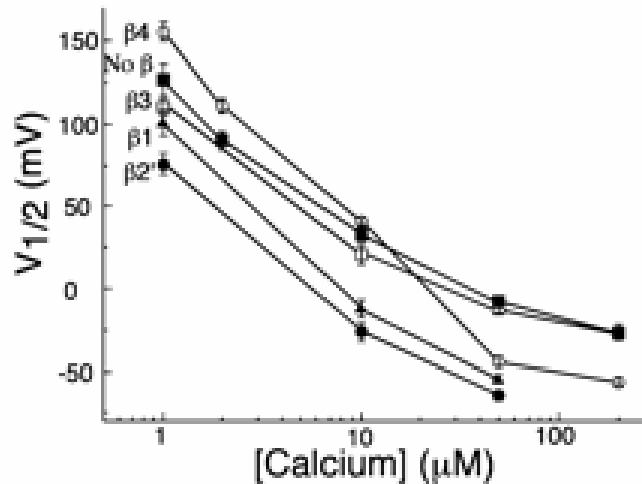

Figure 10. β -subunit modulation of calcium sensitivity. Plot of $V_{1/2}$ versus log calcium concentrations. Currents were evoked in inside-out macro-patches perfused on the intracellular side with an isometric potassium and buffered calcium solution. Normalized conductance was measured for each test potential from the current amplitude taken 200 μ s after repolarization to -80 mV in oocytes transfected with various BK channel constructs. Adapted from Brenner et al., 2000.

In addition to shifting calcium sensitivity, coexpression of α with either the β 1 or β 4 subunit slows activation kinetics with β 4 showing the most significant slowing relative to α alone (Behrens et al., 2000). Furthermore, β 4-containing channels have slower gating kinetics than α channels alone. Additional expression studies have shown that human α , $\alpha\beta$ 1, or $\alpha\beta$ 4 channels all have similar single channel conductances (Feinberg-Zadek and Treistman, 2007).

Properties of Various α Splice Variants Coexpressed with β Subunits

Little is known about the properties of different α splice variants coassembled with auxiliary β subunits. This is further complicated by unknowns surrounding the exact stoichiometry of β subunits to α subunits and whether α or β subunits are homomeric or heteromeric. As mentioned previously, one STREX α subunit in the tetrameric channel assembly is sufficient to alter the channels response to PKA activators from potentiation to inhibition (Tian et al., 2004) suggesting that certain α isoforms may present more dominant phenotypes than others. Recently Petrik and Brenner coexpressed either STREX or Insertless isoforms with the auxiliary β_4 subunit and described their properties. Surprisingly, the properties conferred by the individual subunits were non-additive and sometimes completely opposite (Petrik and Brenner, 2007).

BK Channels in the Hypothalamic-Neurohypophysial System

The hypothalamic-neurohypophysial system (HNS) provides an ideal model system to study the acute effects of ethanol and the development of tolerance. In the HNS, magnocellular and parvocellular neurons of the supraoptic nucleus (SON) send axonal projections to the posterior pituitary (neurohypophysis) where they terminate in millions of nerve endings which release oxytocin (OXT) or arginine vasopressin (AVP) into systemic circulation (Morris and Pow, 1993). A schematic of the HNS system is provided in Figure 11. It is well known that short-term ethanol challenge reduces the release of AVP, an

anti-diuretic peptide hormone from the neurohypophysis contributing to the increased urge to urinate after drinking (Crabbe et al., 1981; Pohorecky, 1985a; Pohorecky, 1985b). However, after chronic ethanol exposure release of AVP returns to baseline, providing an illustrative example of acquired tolerance (Knott et al., 2000; Knott et al., 2002).

In the HNS BK channels have been identified as direct targets for ethanol action in the neurohypophysis (Jackson et al., 1991; Dopico et al., 1998; Chu et al., 1998; Knott et al., 2000; Knott et al., 2002). In addition, due to their ability to couple membrane potential and intracellular calcium levels, BK channels presumably indirectly limit calcium influx into the terminals. For these reasons, BK channels in the neurohypophysis are postulated to play a role in mediating the effects of alcohol on peptide release.

In addition to being acutely potentiated by alcohol, BK channels in terminals also develop two components of acute tolerance. First, channels show a reduction in potentiation which occurs within a few minutes of alcohol exposure. Second, there is a reduction in current density, that occurs after several hours of alcohol administration (Pietrzykowski et al., 2004). It is unknown whether these two components are linked by an underlying mechanism or whether they occur independently. Furthermore, it is unknown how long these phenomena persist in the absence of the drug.

Interestingly, while BK channels in the neurohypophysis are acutely sensitive to low concentrations of alcohol, BK channels in SON cell bodies are

alcohol insensitive (Dopico et al., 1999b). Furthermore, channels in these two subcellular compartments display differential sensitivities to channel blockers suggesting the two populations represent different subtypes of BK channels. Similar to neurohypophysial terminals, SON neurons secrete AVP and OXT centrally into the brain (reviewed in Ludwig and Leng, 2006). However, in contrast to the neurohypophysis little is known regarding the effects of alcohol on somatodendritic peptide release. Therefore, one of the aims of this project was to determine whether the effect of alcohol on BK channels, differs between the dendritic, somatic, and nerve terminal compartments. My data not only yielded information about the selective regional distribution of alcohol sensitive and insensitive channels in the HNS, but also has important implications for understanding how alcohol modulates synaptic integration.

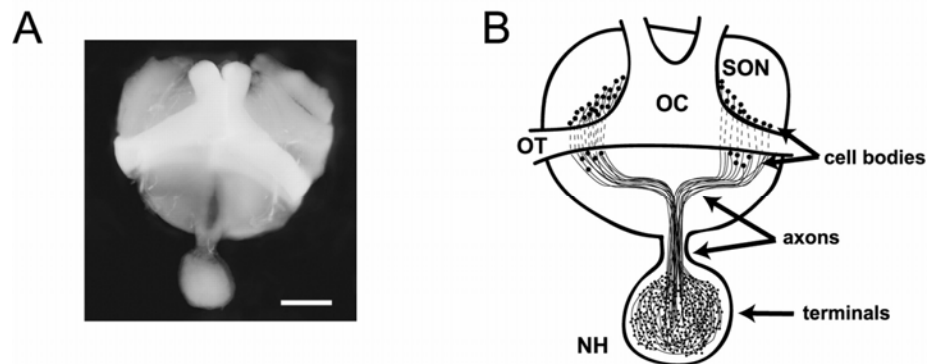

Figure 11. Bright field image and schematic diagram of HNS system. (A) Bright field to view of HNS system. (B) Diagram of HNS shown in panel A showing the position of the magnocellular compartments (cell bodies, axons, and terminals). Supraoptic nucleus (SON), optic chiasm (OC), optic tract (OT), neurohypophysis (NH). Figure adapted from Pietrzykowski et al., 2004.

The Mesolimbic-Dopaminergic Pathway

To further explore how alcohol affects BK channels I chose to shift gears from the HNS system to the mesolimbic-dopaminergic pathway, a region heavily implicated in addiction. The mesolimbic-dopaminergic pathway is a neural circuit that links the ventral tegmentum in the midbrain to the nucleus accumbens in the striatum and is often referred to as the “reward pathway”. It is one of the four major pathways where the neurotransmitter dopamine is found. This brain circuitry is activated by rewarding stimuli including food, sex and addictive drugs such as alcohol. The mesolimbic pathway is thought to be involved in producing pleasurable feeling, and is often associated with feelings of reward and desire, particularly because of the connection to the nucleus accumbens, which is associated with these states.

Within the striatum, BK channels play a role in modulating action potentials and are sensitive to alcohol (Martin et al., 2004; Martin et al., 2008). However, it was previously unknown whether BK channels in this region of the brain developed tolerance. Therefore, another aim of my project was to determine whether BK channels in the nucleus accumbens developed tolerance and whether the persistence of tolerance was dependent on (1) duration of alcohol exposure and (2) continued presence of the drug. In order to explore these ideas I developed a striatal culture from postnatal day 8 rat pups which would allow me to precisely administer and withdraw alcohol for defined periods of time.

Chapter One

**Compartmentalized β Subunit Distribution Determines
Characteristics and Ethanol Sensitivity of Somatic, Dendritic,
and Terminal BK Channels in the Rat CNS**

As submitted for publication in the Journal of Pharmacology and Experimental
Therapeutics.

Abstract

Neurons are highly differentiated and polarized cells, whose various functions depend upon the compartmentalization of ion channels. The rat hypothalamic-neurohypophysial system (HNS), in which cell bodies and dendrites reside in the hypothalamus, physically separated from their nerve terminals in the posterior pituitary (neurohypophysis), provides a particularly powerful preparation in which to study the distribution and regional properties of ion channel proteins. Using electrophysiological and immunohistochemical techniques we characterized the BK channel in each of the three primary compartments (soma, dendrite, and terminal) of HNS neurons. We find that dendritic BK channels, in common with somatic channels, but in contrast to nerve terminal channels, are insensitive to iberiotoxin. Furthermore, analysis of dendritic BK channel gating kinetics indicates that they, like somatic channels, have fast activation kinetics, in contrast to the slow gating of terminal channels. Dendritic and somatic channels are also more sensitive to calcium and have a greater conductance than terminal channels. Finally, while terminal BK channels are highly potentiated by ethanol, somatic and dendritic channels are insensitive to the drug. The biophysical and pharmacological properties of somatodendritic vs. nerve terminal channels are consistent with the characteristics of exogenously expressed $\alpha\beta 1$ vs. $\alpha\beta 4$ channels, respectively. Therefore, one possible explanation for our findings is a selective distribution of $\beta 1$ subunits to the somatodendritic compartment and $\beta 4$ subunits to the terminal compartment. This hypothesis is supported

immunohistochemically by the appearance of distinct punctuate $\beta 1$ or $\beta 4$ channel clusters in the membrane of somatodendritic or nerve terminal compartments, respectively.

Introduction

Ion channel compartmentalization between different brain regions and neuronal populations has been studied for many years. Recently, technological advances have permitted researchers to probe the distribution of channel subtypes at a subcellular level. Here we have utilized a unique system, the hypothalamic-neurohypophysial system (HNS), which allows us to examine dendrites, cell bodies, and individual nerve terminals within the same population of magnocellular neurons (MCNs). The HNS is an ideal model system to study compartmentalization of channel properties because the three neuronal domains (dendrite, cell body, and nerve terminal) can be easily distinguished from one another. The large (20-30 μm) magnocellular neurons of the supraoptic nucleus (SON) send axonal projections to the posterior pituitary (neurohypophysis) where they each terminate in thousands of nerve endings which release oxytocin (OXT) or vasopressin (AVP) into systemic circulation (Morris and Pow, 1993). MCN dendrites, on the other hand, project toward the ventral surface of the brain forming a dense interlaced network that releases OXT or AVP centrally (Armstrong, 1995). Morphologically, HNS axons have few if any collaterals, allowing them to be easily distinguished from dendrites (Theodosis, 1985).

Large conductance calcium activated potassium (BK) channels play a prominent role in cellular excitability from repolarizing neuronal action potentials to modulating contractility in vasculature (Liu et al., 2004; Fernandez-Fernandez et

al., 2004;Toro et al., 1998). They are found ubiquitously throughout the brain and are highly conserved in mammals (Toro et al., 1998). BK channels are activated by both cell membrane depolarization and increases in intracellular calcium (Ghatta et al., 2006), allowing them to function as coincidence detectors that integrate intracellular calcium levels and membrane voltage. BK channels may be homomeric or heteromeric and are composed of four seven-transmembrane α subunits which form the selectivity pore of the channel.

Currently, four β subunits (β 1- β 4) have been cloned and characterized. Association of the α subunit with various β subunits modulates channel properties, including kinetic behavior, voltage dependence, calcium sensitivity, and pharmacological attributes such as sensitivity to the channel blockers, iberiotoxin and charybdotoxin (Dworetzky et al., 1996;Behrens et al., 2000;Brenner et al., 2000;Meera et al., 2000;Weiger et al., 2000;Lippiat et al., 2003). To date, studies examining the regional distribution of BK β subunits indicate that they are relatively tissue specific. β 1 subunits are localized primarily in smooth muscle, showing less expression in the brain (Knaus et al., 1994;Giangiacoamo et al., 1995;Jiang et al., 1999;Wanner et al., 1999). β 2 subunit expression is especially abundant in ovaries, while β 3 shows the highest expression in the pancreas and testis. Both β 2 and β 3 subunits are only weakly detected in other tissues, including brain (Wallner et al., 1999;Brenner et al.,

2000). In contrast to the other β subunits, $\beta 4$ is highly expressed in brain and only weakly detected in other tissues.

On the subcellular level, few studies have attempted to describe BK channel distribution, characterization, and subunit composition in all three compartments of a neuron. Studies have described the immunolocalization of BK channels in the dendrites and nerve terminals of hippocampal pyramidal neurons, but did not biophysically characterize or identify the subunit composition of the channels (Sailer et al., 2006). In another example, the biophysical properties of dendritic and somatic BK channels in layer 5 pyramidal neurons of the somatosensory cortex were identical, but did not examine channels in nerve terminals (Benhassine and Berger, 2005). We have previously reported that dendritic and somatic BK channels in rat nucleus accumbens neurons display different biophysical properties, which could be explained by a predominance of BK $\beta 1$ subunits in the dendritic compartment and BK $\beta 4$ subunits in the cell body (Martin et al., 2004). Again, due to limitations of the preparation, this study was unable to examine BK channels in nucleus accumbens nerve terminals. Here, we focus on BK channels within HNS magnocellular neurons, and describe the characteristics of BK channels in each of the three major compartments of a CNS neuron. These findings may have particular functional significance in understanding how peptide release from the somatodendritic and nerve terminal compartments is differentially regulated (reviewed in Ludwig and Leng, 2006).

Materials and Methods

Isolated SON Cell Bodies

Adult Sprague Dawley rats (150-250 g) were decapitated, the brain removed and placed into a dish containing oxygenated ice-cold (4°C) high sucrose cutting solution. 500 µm slices were obtained using a Vibroslicer, the SON isolated with the aid of a dissecting microscope, and transferred to an oxygenated (100% O₂ with constant stirring) HBSS solution containing Protease XIV from *Streptomyces griseus* (Sigma-Aldrich, St. Louis, MO) for 15 minutes. The SON disks were then transferred to EBSS (holding) solution oxygenated with 95%O₂/5%CO₂ for 45 minutes. The tissue was then mechanically triturated in sodium isethionate solution using fire polished Pasteur pipettes with successively smaller tip diameters. Dissociated cell bodies were then transferred to a 35 mm Petri dish placed on the stage of an inverted microscope (Nikon Diaphot). The cells were allowed to settle for 15 min before perfusing with 60 ml regular Locke's solution at a rate of 4 ml/min. Electrophysiological recordings were subsequently obtained from either the cell body or dendrite. In contrast to axons, which have a uniform width and lack any branches, dendrites were identified morphologically by their tapered appearance and branching (Figure 1A).

Isolated Neurohypophysial Terminals

The neurohypophysis was removed from the animal within 1 min of sacrifice and placed in low-calcium Locke's solution. To expose the neurohypophysis, the

pars intermedia was dissected away and discarded. Terminals were homogenized in a solution containing in mM: 270 sucrose, 10 HEPES, and 1 mM EGTA, pH 7.3, as described in (Cazalis et al., 1987) and transferred to a 35 mM dish where they were allowed to settle. The terminals were then processed for immunohistochemistry or electrophysiology. For electrophysiological measurements, dissociated terminals were identified by their spherical shape, approximately 5-10 μm diameter, lack of nuclei, and golden color under Hoffman phase-contrast optics. Prior to ethanol challenge, the terminals were first bathed in low-calcium (3 μM) Locke's solution followed by regular Locke's solution.

Single Channel Recordings

Recording electrodes were pulled (Sutter Instruments, Novato, CA) and fire-polished from borosilicate capillary glass (Drummond, Bromall, PA) to a final resistance of 4-8 M Ω . Currents were recorded in voltage-clamp mode with a HEKA EPC 10 amplifier at a sampling rate of 10 kHz and low-pass filtered at 2.0 kHz with an eight-pole Bessel filter. Potentials and currents were digitized, curve-fit, measured, stored, and plotted using Patchmaster acquisition and analysis software (HEKA Elektronik, Lambrecht/Pfalz, Germany).

Data analysis

NP_0 values were calculated from all-points amplitude histograms by fitting the histogram with a sum of Gaussian functions using a Levenberg–Marquardt algorithm. NP_0 data as a function of voltage were fitted with a Boltzmann function

of the type: $P_o = (1 + \exp - K(V - V_{0.5}))^{-1}$, where K is the logarithmic potential sensitivity and $V_{0.5}$ the potential at which P_o is half-maximal. When the NP_o -voltage relationship is fitted with a Boltzmann curve, a plot of $\ln NP_o$ versus voltage is linear at low values of P_o . In this plot, the reciprocal of the slope is the potential needed to produce an e -fold change in NP_o , which is routinely used to measure the voltage dependence of BK channel gating. The unitary conductance (γ) was taken as the slope of the unitary current amplitude-voltage relationship. Values for unitary current were obtained from the Gaussian fit of all-points amplitude histograms by measuring the distance between the modes corresponding to the closed state and the first opening level. For all experiments, voltages given correspond to the potential at the intracellular side of the membrane.

Macroscopic currents were compiled by summing 100 consecutive single channel traces obtained by stepping the membrane of an inside-out patch from a holding potential of 0 mV to + 40 mV, in the presence of 10 μ M free- Ca^{2+} . Leak currents were subtracted on-line. To yield the macroscopic current, traces were summed and the activation kinetics subsequently fit using Fitmaster software (HEKA Elektronik, Lambrecht/Pfalz, Germany).

Ethanol and Iberiotoxin Application

Recording electrode tips were positioned in the 'mouth' of the perfusion pipe (hematocrit tubes) to prevent contamination from solutions potentially leaking

from nearby tubes. Three 20 s control traces in the presence of 5 μM free- Ca^{2+} solution were taken to determine baseline channel activity. Ethanol or iberiotoxin were applied to inside-out or outside-out patches, respectively.

Experimental Solutions

High potassium pipette solution contained the following in mM: 135 K-Gluconate, 1 MgCl_2 , 2.2 CaCl_2 , 15 HEPES, 4 EGTA, and 4 HEDTA. Regular Locke's solution contained the following in mM: 2 KCl, 142 NaCl, 2 MgCl_2 , 2 CaCl_2 , 13 glucose, and 15 HEPES. Excised patches were exposed to (in mM): 135-140 K-gluconate, 0-4 HEDTA, 0-4 EGTA, 15 HEPES, 1 MgCl_2 , and 0.5-2.2 CaCl_2 . HEDTA, EGTA, and CaCl_2 concentrations were adjusted to obtain the desired concentrations of free calcium, ranging from 1 to 25 μM free- Ca^{2+} . Free- Ca^{2+} concentrations were determined by the Max Chelator Sliders software (C. Patton, Stanford University) and confirmed with a Kwik-Tip calcium probe (World Precision Instruments, Sarasota, FL).

Immunohistochemistry

To stain the SON, a block of brain tissue was fixed in 4% paraformaldehyde (PFA). After immersion in 20% sucrose, tissue was embedded in 6% gelatin-egg yolk mixture and exposed to concentrated formaldehyde vapors for at least 3 days (4°C). After hardening, 50 μM coronal sections were cut on a freezing microtome, placed in 1X PBS, and transferred to wells. HNS terminals were

dissociated, as described previously, allowed to settle for 15 min on glass bottom culture dishes (MatTek, Ashland, MA), and fixed in 4% PFA. Both the terminals and SON tissues slices were then permeabilized and blocked in a solution containing 10% NGS, 0.1% BSA, 0.4% Triton-X 100 in PBS/0.02% sodium azide, pH 7.4, for 1 hr at room temperature.

Permeabilized SON sections were incubated with primary antibodies to polyclonal anti-BK β 1 (1:100; Alomone, Jerusalem, Israel) or polyclonal anti-BK β 4 subunit (1:100; Alomone, Jerusalem, Israel) overnight at 4°C. After incubation, SON slices were rinsed and incubated for 1 hr at room temperature with Alexa 488-tagged anti-rabbit secondary antibody (1:300; Molecular Probes, Eugene, OR) for 1 hr at room temperature. After rinsing, SON sections were incubated with goat anti-vasopressin (1:100, Santa Cruz Biotechnology, Santa Cruz, CA) for 2 hours at room temperature, rinsed, and incubated with Alexa 594-tagged anti-goat secondary antibody. After ample washing with PBS, SON tissue slices were mounted on microslides (SuperFrost Plus; VWR Scientific, West Chester, PA) using Prolong Antifade medium (Invitrogen, Carlsbad, CA).

Permeabilized nerve terminals were incubated with primary antibodies to polyclonal anti-BK β 1 (1:100; Alomone, Jerusalem, Israel) or polyclonal anti-BK β 4 subunit (1:100; Alomone, Jerusalem, Israel) overnight at 4°C. After incubation, terminals were rinsed and incubated for 1 hr at room temperature

with Alexa 594-tagged anti-rabbit secondary antibody (1:300; Molecular Probes, Eugene, OR) for 1 hr at room temperature. After rinsing, terminals were incubated with goat anti-vasopressin (1:100, Santa Cruz Biotechnology, Santa Cruz, CA) for 2 hours at room temperature, rinsed, and incubated with Alexa 350-tagged anti-goat secondary antibody. After after rinsing, terminals were incubated with mouse anti-oxytocin (1:100, a gift from Dr. H. Gainer, NIH, Bethesda, MD) for 2 hours at room temperature, rinsed, and incubated with Alexa 488-tagged anti-mouse secondary antibody for 1 hour at room temperature. Coverslips were placed in glass bottom culture dishes using Prolong Antifade medium (Invitrogen, Carlsbad, CA). Control experiments were performed to insure the specificity of primary antibodies (anti- β 1 and anti- β 4) by adding commercially available blocking peptide which completely ablated staining. A Zeiss Axiovert inverted microscope and Axiovision 4.5 software package (Carl Zeiss, Inc., Thornwood, NY) were used to acquire and deconvolve Z-stacks of fluorescent images, and perform subsequent analysis.

Statistics

Unless otherwise indicated, statistical significance between various groups was analyzed using Student's t test (Statistica, version 5.5; StarSoft, Tulsa, OK). All data are expressed as mean \pm SEM, and $p < 0.05$ were considered to be statistically significant.

Results

SON dendrites express functional BK channels

Previous studies reported the presence of BK channels in SON cell bodies and neurohypophysial terminals of the HNS system (Wang et al., 1992; Dopico et al., 1999b). In order to extend the characterization of BK channels to include the dendritic compartment, we first confirmed that BK channels are present in the dendrite. Figure 1A shows a micrograph of a micropipette placed on a dendrite. We assessed basic electrophysiological properties including voltage sensitivity, calcium sensitivity, and conductance of dendritic channels in inside-out patches. Dendritic single channel currents were elicited by depolarizing the membrane from -80 mV to +80 mV in 20 mV increments while perfusing the intracellular surface with 5 μM free- Ca^{2+} . The activity of a two-channel patch recorded between -40 mV and +40 mV is shown in Figure 1B. At -40 mV, the channels display a low open probability ($\text{NPo} = 0.097$) but as the membrane is depolarized to +40 mV the channels spend more time in the open state ($\text{NPo} = 0.92$). The same patch was then clamped at -40 mV and the cytosolic face exposed to 1, 5, and 10 μM free- Ca^{2+} . The channels are extremely calcium dependent, exhibiting low activity in 1 μM free- Ca^{2+} ($\text{NPo} = 0.001$), increasing activity to an NPo of 0.169 in the presence of 5 μM free- Ca^{2+} , and reaching a nearly persistent open state in 10 μM free- Ca^{2+} ($\text{NPo} = 0.79$) (Figure 1C). Figure 1D shows a plot of the current amplitude vs. the membrane potential of a dendritic channel. The current-voltage relationship was well-fitted with a linear regression ($r = 0.99$).

yielding a slope conductance of 261 pS. In addition, current reversed at 0 mV in symmetric potassium conditions, $[K]_i = [K]_o$, indicating the channel is selective for potassium. These data are consistent with the known features of BK channels including potassium selectivity, large conductance (>180 pS), and sensitivity to intracellular calcium (McManus, 1991).

In order to dependably compare the properties of BK channels in each of the three compartments, we repeated previously published characterizations of several BK channel parameters in the HNS cell body and nerve terminal in addition to those performed in the dendrite.

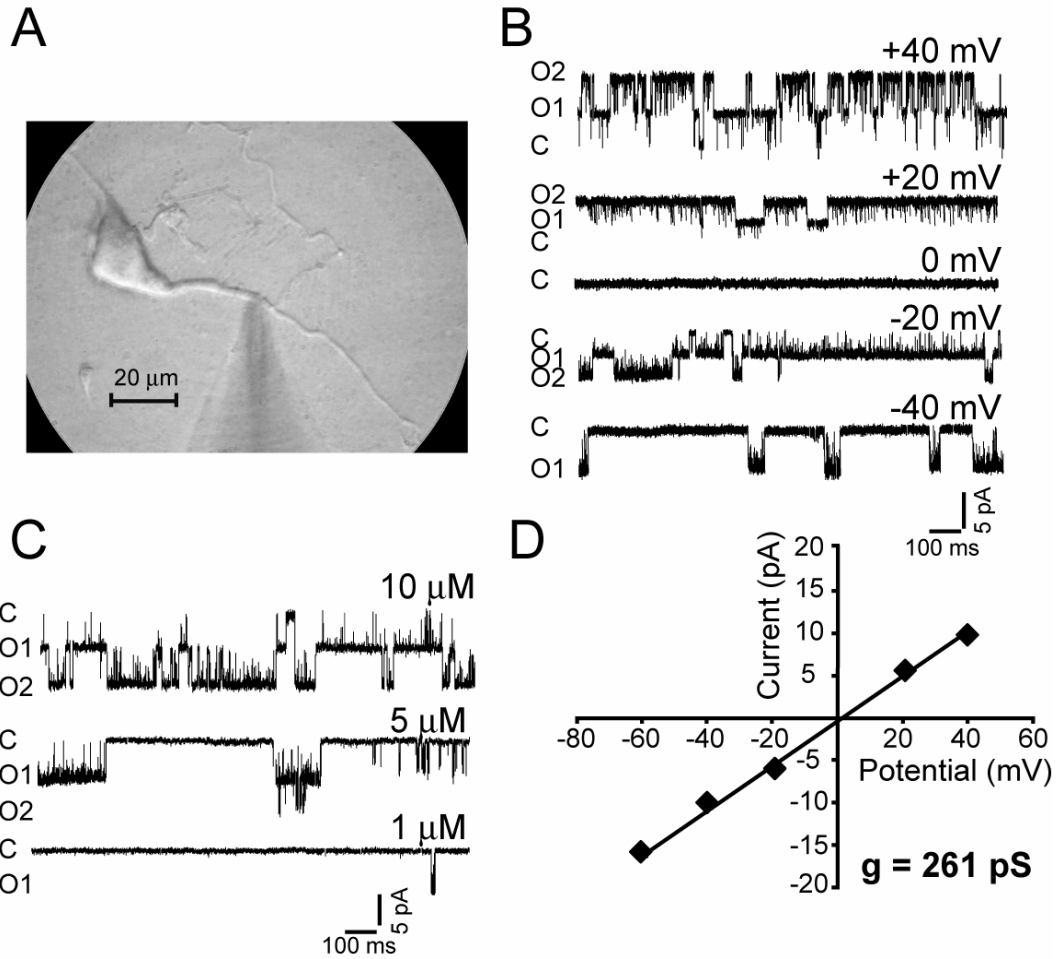

Figure 1. Voltage and calcium dependence of dendritic BK channels of HNS magnocellular neurons. (A) Micrograph of a recording electrode positioned on the dendrite of a dissociated SON neuron. (B) Activity of two dendritic BK channels, recorded in inside-out patch clamp configuration in the presence of $5 \mu\text{M}$ free- Ca^{2+} , increases as the membrane is depolarized. (C) Traces recorded at -40 mV in the same patch as in B show the dependence of channel activity on intracellular calcium ($1\text{-}10 \mu\text{M}$). (D) Plot of BK channel current amplitude as a function of membrane potential. A linear fit of this relationship ($r = 0.99$) gave a BK channel unitary conductance of 261 pS . C and O represent the closed and open states, respectively.

Conductance

In symmetric 135 mM K^+ , with the intracellular face of inside-out patches exposed to 5 μM free- Ca^{2+} , the conductance of dendritic BK channels was 247.0 ± 11.2 pS, $n = 7$. In contrast, under identical conditions BK channels in nerve terminals had a conductance of 219 ± 4.84 pS, $n = 4$ (Figure 2A) consistent with previously reported values (Pietrzykowski et al., 2004). Values obtained for cell body channels, 250.7 ± 9.4 pS ($n = 9$) in 5 μM free- Ca^{2+} were very similar to dendritic channels. When exposed to 10 μM free- Ca^{2+} the conductance of somatic and dendritic channels was again similar, 248.3 ± 14.5 pS ($n = 8$) and 254 ± 7.03 pS ($n = 6$), respectively (Figure 2B).

Calcium Dependence

Figure 2C shows the normalized NPo of BK channels from SON terminals, soma, and dendrites as a function of membrane potential. The graph shows that the open probability of BK channels is steeply voltage dependent. The NPo-voltage relationship could be well-fitted with a Boltzmann equation. Consistent with previous data, nerve terminal BK channels were less sensitive to 10 μM free- Ca^{2+} than somatic channels ($V_{0.5}$ was -8.9 ± 3.5 mV, $n = 7$ in terminals and -30.6 ± 3.7 mV, $n = 7$ in cell body). Dendritic BK channels showed sensitivity to 10 μM free- Ca^{2+} similar to somatic channels ($V_{0.5}$ was -22.5 ± 4.2 mV, $n = 9$) (Figure 2C). In addition, the voltage necessary to produce an e-fold change in open probability (see Methods; reciprocal of the slope of the $\ln(\text{Po})$ -V relationship at

low P_o) was similar for both somatic and dendritic SON channels (10.7 ± 1.5 and 11.6 ± 1.4 , respectively). In the terminals, however, the voltage necessary to produce an e -fold change in open probability was 24 ± 2.8 mV. Taken together, these data suggest a relatively homogeneous BK channel profile in the somatodendritic compartment, which is markedly different from the channel population in the nerve terminal.

Because of the heavy dependence of BK channel open probability on calcium concentration we determined whether the similarity between dendritic and somatic BK channels open probability extended across a range of calcium concentrations. As shown in Figure 2D, the open probability of BK channels is steeply calcium and voltage dependent, as the calcium concentration is decreased the membrane must be depolarized more to produce a similar open probability (seen as a shift to the right). The graph shows the similarity between cell body and dendritic channels obtained from an examination of channel activity in 25 μM , 10 μM , and 5 μM free- Ca^{2+} . The potential at which half of the BK channels were open ($V_{0.5}$) in 25 μM free- Ca^{2+} was -65.6 ± 2.9 mV ($n = 12$) and -68.7 ± 3.3 mV ($n = 10$) in the soma and dendrites, respectively. In 10 μM free- Ca^{2+} $V_{0.5}$ was -30.6 ± 3.7 mV ($n = 7$) and -22.5 ± 4.2 mV ($n = 9$) in the soma and dendrites, respectively. Finally, in 5 μM free- Ca^{2+} $V_{0.5}$ was 8.5 ± 3.7 mV ($n = 8$) and 13.1 ± 1.9 mV ($n = 11$) in the soma and dendrites, respectively (Figure 2D). In summary, we found that the NPo-voltage relationship of dendritic and somatic

channels is indeed very similar across a range of calcium concentrations.

Furthermore, the NPo-voltage relationship of dendritic and somatic channels is different from terminal channels.

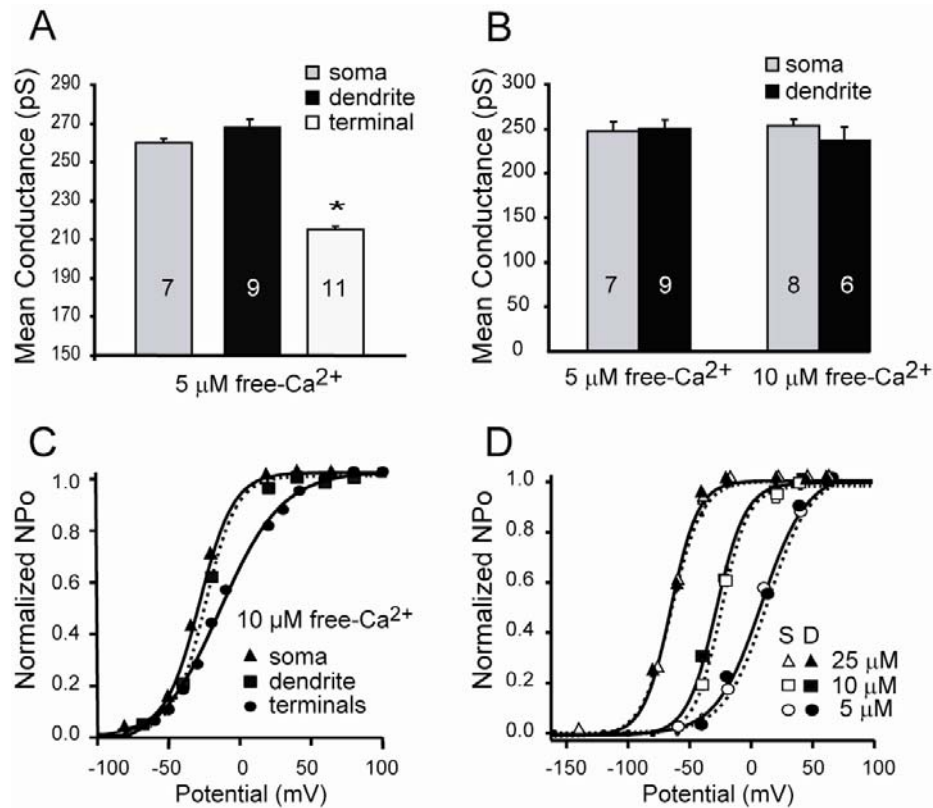

Figure 2. Comparison of the conductance and calcium dependence of somatic, dendritic, and nerve terminal BK channels. (A) Mean conductance of somatic, dendritic, and nerve terminal channels measured in the presence of 5 μM free- Ca^{2+} . (B) Mean conductance of somatic and dendritic channels measured in the presence of 5 and 10 μM free- Ca^{2+} . (C) Normalized NPo-Voltage relationship of SON somatic and dendritic channels compared to SON nerve terminal channels in 10 μM free- Ca^{2+} (SEM not shown to reduce clutter). Somatic, dendritic, and nerve terminal are shown as triangles, squares, and circles, respectively. (D) Plots of normalized mean NPo as a function of voltage at different $[\text{Ca}^{2+}]_i$; circles, 5 μM ; squares, 10 μM ; triangles, 25 μM . Open and filled symbols represent soma and dendrite, respectively. The NPo-V relationship, fitted with a Boltzmann equation, is shifted along the voltage axis to more negative potentials as $[\text{Ca}^{2+}]_i$ increases.

Activation kinetics differs between somatodendritic and nerve terminal BK channels.

Although whole-cell patch clamp is generally used to study kinetic properties such as activation, we could not use this approach, because it would not have enabled us to independently examine BK channel properties in each region of the cell. Moreover, single channel records assure that our data is not contaminated with non-BK currents. Therefore, to study channel kinetics we compiled a cumulative current trace from the summation of 100 repetitively evoked single channel sweeps. The resulting current trace resembles the classical macroscopic current recorded in whole-cell patch clamp configuration. The membrane of an inside-out patch was stepped from a holding potential of 0 mV to + 40 mV in the presence of 10 μM free- Ca^{2+} . A typical example showing 7 of 100 consecutive traces from somatic, dendritic, and nerve terminal channels is shown in Figures 3A-C. An example of the compiled macroscopic current from the soma, dendrite, and nerve terminal is shown in Figures 3D-F. In both the cell body and dendrite, currents were well fitted with a single exponential, τ was 3.4 ± 1.18 ms ($n = 6$) in the soma and 5.7 ± 2.34 ms ($n = 7$) in the dendrites, respectively, indicating these channels have relatively fast activation kinetics. In contrast, nerve terminal channels display much slower gating kinetics, $\tau = 22.7 \pm 4.19$ ms, $n = 3$ consistent with previous studies (Wang et al., 1992; Dopico et al., 1999b).

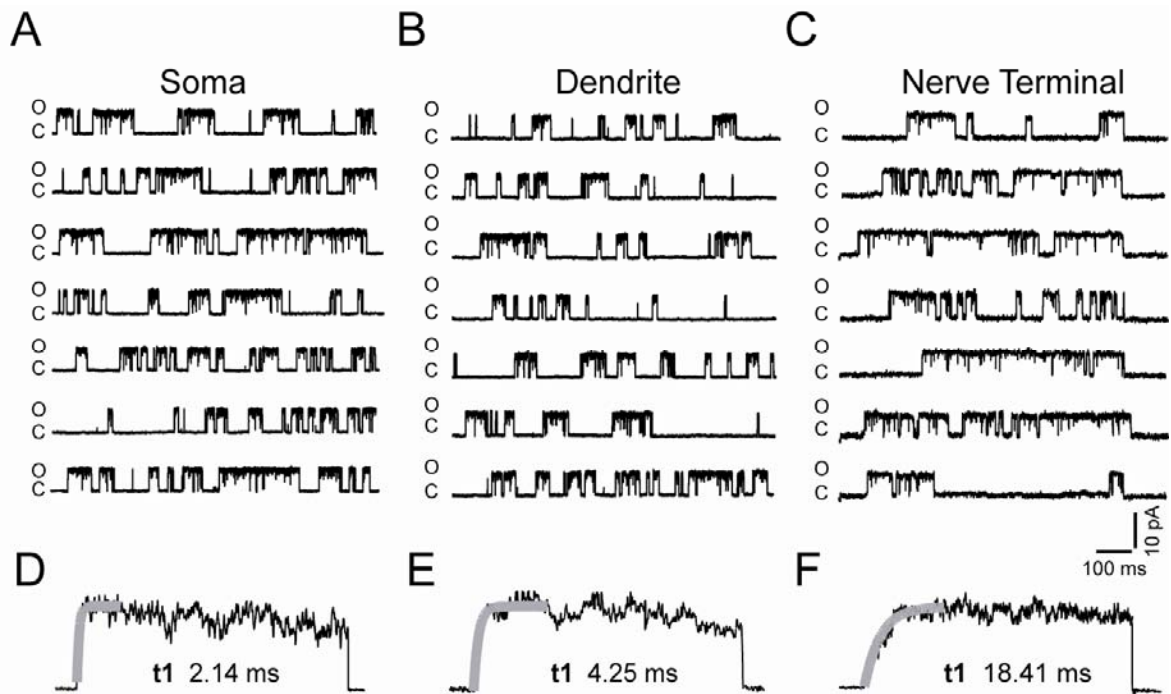

Figure 3. Gating properties of nerve terminal channels differ from that of somatic and dendritic channels. A series of seven consecutive BK traces evoked by depolarizing (A) somatic, (B) dendritic, or (C) nerve terminal membrane patches from 0 to +40 mV. Channel activity was recorded in 10 μ M free- Ca^{2+} in an inside-out patch. Averaged currents for each compartment represent the aggregate of 100 individual single channel traces. In all cases, BK current activation was best fit with a single exponential (see Materials and Methods).

Ethanol selectively potentiates nerve terminal but not somatodendritic BK channels.

The BK channel is a well-studied target of ethanol action, and while BK channels in HNS terminals are highly sensitive to ethanol, exhibiting increased channel activity within a few minutes, BK channels in the cell body of these neurons are insensitive to the drug (Dopico et al., 1996; Dopico et al., 1999a). Here, we examine the sensitivity of dendritic BK channels. The ethanol sensitivity of BK channels in proximal dendrites (20-40 μM from the soma) was examined in inside-out patches in the presence of 5 μM free- Ca^{2+} at a membrane potential of -40 mV. The ethanol concentrations chosen were within a clinically relevant range from 20 mM EtOH (resulting in intoxication) to 100 mM EtOH (lethal in naïve subjects) (Madeira et al., 1993; Ruela et al., 1994). In the dendrite, the baseline probability of BK channel opening is low ($n\text{Po} = 0.142$) at -40 mV. During application of 50 mM EtOH, channel activity was recorded every 60 seconds for 10 minutes. Throughout the entire period of EtOH exposure channel activity remained unchanged (99 ± 14 % of control; $n = 4$) (Figure 4A/D). Similar results were obtained with 25 and 100 mM ethanol (99 ± 19 % of control values ($n = 4$) and 107 ± 29 % of control ($n = 4$), respectively) (Figure 4D). Neither 25 nor 50 mM EtOH potentiated somatic channels (102 ± 17 % ($n = 3$), and 111 ± 16 % of control ($n = 3$), respectively) (Figure 4B/D) further supporting the notion that cell body and dendrite channels are similar. In contrast, 50 mM EtOH greatly potentiated the activity of channels in dissociated nerve terminals ($673 \pm 171\%$, n

= 3), consistent with previous data (Dopico et al., 1996; Pietrzykowski et al., 2004) (Figure 4C/D). We did not observe any channels that were inhibited by the drug. Furthermore, in control experiments there was no significant deviation in baseline channel activity throughout a 15 minute time period when the patches were perfused with an ethanol-free, 5 μm free- Ca^{2+} solution (data not shown).

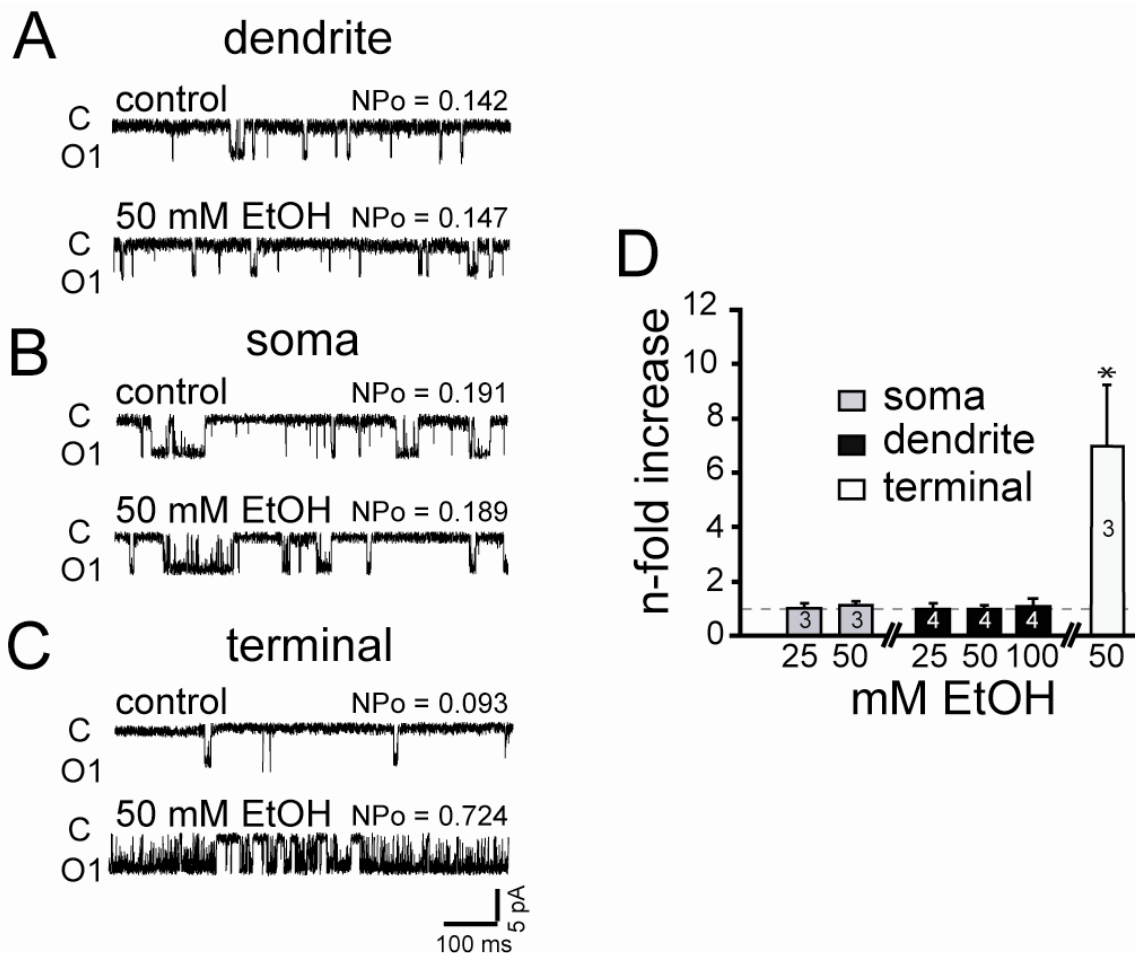

Figure 4. Ethanol (EtOH) exposure increases BK channel activity in the nerve terminal but not in soma or dendrite. Traces of BK channel activity before and during exposure to 50 mM EtOH ($V_h = -40$ mV, $5 \mu\text{M free-Ca}^{2+}$) in (A) dendrite, (B) soma, or (C) nerve terminal patches. C and O represent the closed and open state, respectively. (D) Plot of the effects of various EtOH concentrations on somatic, dendritic, and terminal BK channels. The numbers within the bars represent the number of patches tested. The asterisk indicates statistical significance of $p < 0.01$.

Expression of BK β subunits in the three compartments of the HNS.

One possible explanation for these findings is a selective regional distribution of the auxiliary $\beta 1$ subunit to the somatodendritic compartment, and $\beta 4$ subunit to the terminal compartment. Iberitoxin provides a useful pharmacological tool to distinguish $\alpha\beta 4$ from α or $\alpha\beta 1$ channels. Expression studies have shown that α or $\alpha\beta 1$ BK channels are blocked by nanomolar concentrations of the scorpion toxins, iberitoxin and charybdotoxin, while presence of the $\beta 4$ subunit renders BK channels insensitive to these toxins (Hanner et al., 1998; Behrens et al., 2000; Meera et al., 2000; Lippiat et al., 2003). To assess iberitoxin sensitivity, outside-out patches held at +40 mV and were perfused with 100 nM iberitoxin (IbTX) in 5 μM free- Ca^{2+} . IbTX strongly inhibited both dendritic channels (nPo decreased 81% and 75%, n = 2) and somatic channels (nPo decreased 83% and 71%, n = 2) (data not shown). IbTX blockade of somatic channels is consistent with previously reported findings (Dopico et al., 1999b). In contrast, IbTX had no effect on BK channels in the terminal (nPo changed 0.5% and 0.2%, n = 2) (data not shown) consistent with previously reported findings that terminal channels are insensitive to blockade by the scorpion toxin, charybdotoxin (Wang et al., 1992). These data support the notion that $\alpha\beta 4$ channels are present in the nerve terminal, and absent in both the cell body and dendrite. However, since both α channels and $\alpha\beta 1$ channels are iberitoxin sensitive we were unable to use this pharmacological tool to establish the selective presence of the $\alpha\beta 1$ channel in the cell body and dendrite.

To determine whether $\beta 1$ subunits were present in the somatodendritic compartment, we immunolabeled coronal sections of rat SON tissue with polyclonal antibodies to $\beta 1$ or $\beta 4$ and AVP neurophysin, a known marker for HNS neurons (Figure 5). Magnocellular SON neurons were further identified from parvocellular neurons by their large size, approximately 18 to 25 μm . The punctate anti- $\beta 1$ staining indicates that BK $\beta 1$ channel clusters are located throughout the cell body, as well as in both proximal and distal dendrites (Figure 5C). In contrast, surrounding regions of the brain had very low to nonexistent $\beta 1$ staining, confirming this antibody is highly specific (Figure 5A). In contrast to the robust $\beta 1$ staining, $\beta 4$ staining in SON cell bodies and dendrites was extremely faint (Figure 5B) suggesting that this subunit is either absent or found in low quantities in this compartment.

To confirm the distribution of $\beta 4$ subunits to the nerve terminal we immunolabeled dissociated terminals with anti- $\beta 1$ or anti- $\beta 4$, anti-AVP neurophysin, and anti-OXT. We then selected terminals ranging in size from 5-10 μm for image analysis. These terminals, when labeled with the same concentrations used to stain the SON, displayed distinct punctuate $\beta 4$ clusters while the $\beta 1$ subunit was barely detectable suggesting that $\beta 4$ subunits are predominantly expressed in HNS nerve terminal (Figure 6). Antibody specificity was appropriately controlled for by either omitting the primary antibody or

preabsorbing with blocking peptide. Additionally, both the anti- β 1 and anti- β 4 antibody have been shown to be immunoreactive in wild-type mice, with no specific staining in β 1- and β 4- deficient mice, respectively (Grimm et al., 2007; Piwonska et al., 2008).

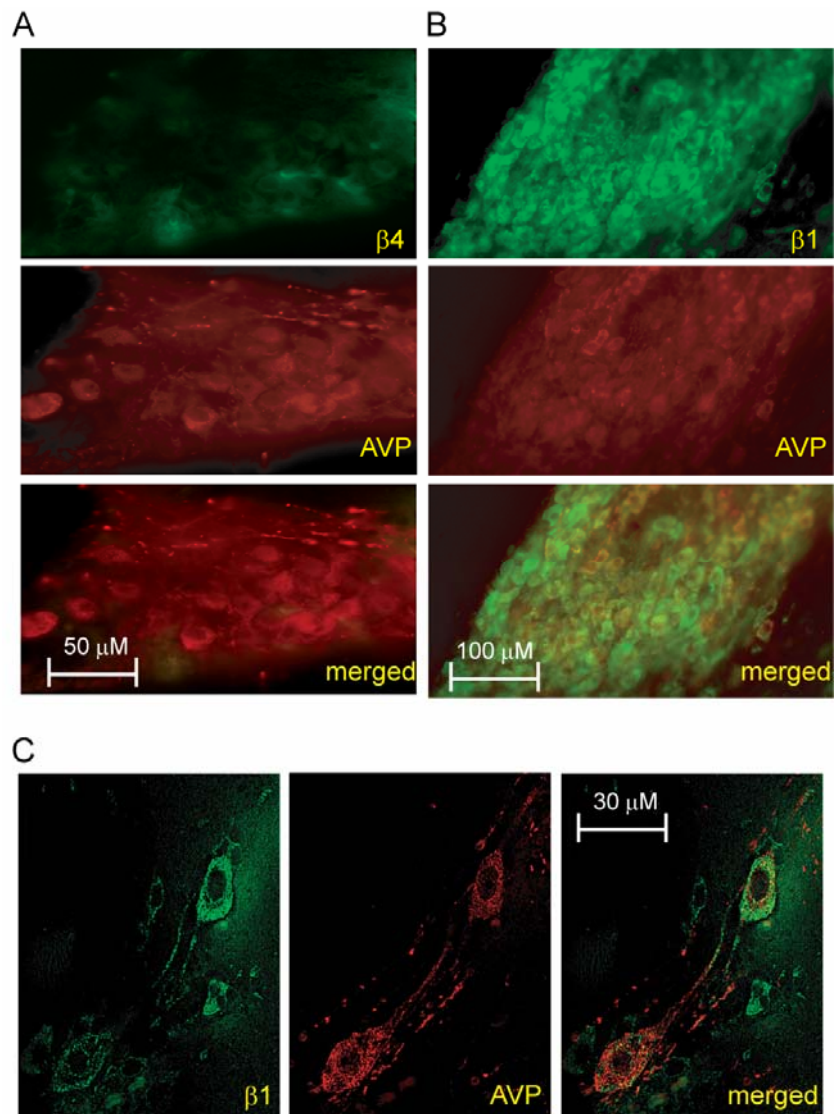

Figure 5. Punctate clusters of BK β 1 subunits are located in the cell body and peripheral processes of magnocellular neurons. 20X magnification of a section from fixed adult rat brain immunolabeled with (A) anti- β 4 followed by

mouse secondary Alexa 488 conjugated antibody or (B) anti- β 1 and Alexa 488 conjugated antibody. (C) 63X magnification of two neurons labeled with anti- β 1 and Alexa 488 conjugated antibody. The sections in panels A-C are counterstained with anti-vasopressin (AVP) neurophysin and Alexa 594 conjugated antibody.

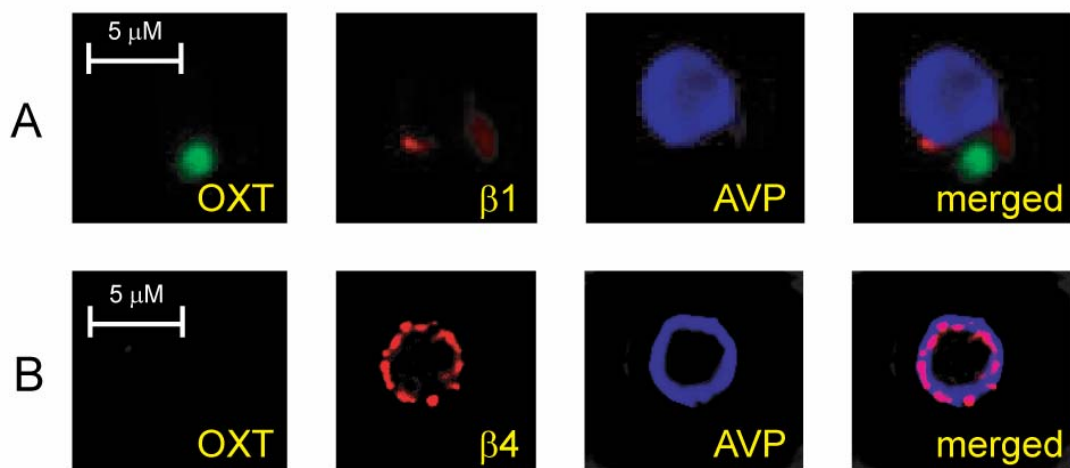

Figure 6. BK β subunits in HNS nerve terminals. A single HNS nerve terminal magnified at 63X immunolabeled with (A) anti- β 1 and mouse secondary Alexa 594 conjugated antibody or (B) anti- β 4 and mouse secondary Alexa 594 conjugated antibody. Nerve terminals are counterstained with (1) anti-vasopressin (AVP) neurophysin and rabbit secondary Alexa 350 conjugated antibody and (2) anti-oxytocin (OXT) and rabbit secondary Alexa 488 conjugated antibody.

Discussion

The data presented in this paper demonstrate: (1) the expression of functional BK channels in dendrites, somata, and nerve terminals of hypothalamic magnocellular neurons; (2) selective expression of $\beta 1$ containing BK channels in cell body and dendrite; (3) selective expression of $\beta 4$ containing BK channels in the nerve terminal; and (4) ethanol potentiation of nerve terminal $\beta 4$ containing BK channels but not somatodendritic $\beta 1$ containing BK channels.

Regional distribution of BK β subunits in three compartments of a single HNS neuron

This study has examined the characteristics of BK channel subtypes in each of the three compartments of a neuron (dendrite, cell body, and nerve terminal) utilizing the unique advantages of the hypothalamic-neurohypophysial system. In doing so, we discovered that in these neurons, BK channels were similar in the somatic and dendritic compartments. In contrast, we observed markedly different BK channels in the nerve terminal. Properties of both cell body and dendritic BK channels include (1) increased calcium sensitivity compared to nerve terminal channels, manifested as a shift in the voltage required to activate the channel to more hyperpolarized potentials, (2) fast activation kinetics, (3) an insensitivity to ethanol, and (4) blockade by iberiotoxin. Properties of exogenously expressed $\alpha\beta 1$ channels match the biophysical and pharmacological properties of HNS somatodendritic channels, suggesting the

presence of $\beta 1$ in this compartment (Jiang et al., 1999;Weiger et al., 2000;Brenner et al., 2000;Feinberg-Zadek and Treistman, 2007).

Nerve terminal channels, on the other hand, display the following properties: (1) decreased calcium sensitivity compared to somatodendritic channels, manifested as a shift in the voltage required to activate the channel to more depolarized potentials, (2) slow activation kinetics, (3) sensitivity to ethanol, and (4) insensitivity to iberiotoxin blockade. Consistent with exogenous $\alpha\beta 4$ expression studies, these biophysical and pharmacological properties suggest that HNS nerve terminal channels contain the $\beta 4$ subunit (Behrens et al., 2000;Brenner et al., 2000;Meera et al., 2000;Weiger et al., 2000;Feinberg-Zadek and Treistman, 2007). Immunostaining with antibodies to either the $\beta 1$ and $\beta 4$ subunit confirmed the regional distribution of BK $\alpha\beta 1$ channels in the somatodendritic compartment and BK $\alpha\beta 4$ channels in nerve terminals.

Regional subcellular distribution of channel subtypes is not limited to BK channels, but has also been reported for other channel types. For example, in the reticular thalamus Kv3.1 voltage gated potassium channel splice variants are differentially distributed such that the Kv3.1b isoform is localized to the soma and proximal dendrites while the Kv3.1a isoform is selectively restricted to axonal processes (Ozaita et al., 2002). There are also reports that T-type calcium channel isoforms selectively distribute to the soma or dendrite dependent upon

neuronal type (McKay et al., 2006). Interestingly, within the HNS system differential distribution patterns of calcium currents have also been observed. P-type calcium current which are omega-agatoxin sensitive are expressed in the cell bodies of magnocellular neurons while omega-conotoxin sensitive calcium currents are expressed in the nerve terminal (Fisher and Bourque, 1995). The selectivity of ion channel distribution emphasizes their important role in cell polarity and neuronal specialization.

A number of mechanisms may underlie the selective distribution of ion channels within neurons. Several mRNA's such as arginine vasopressin, α CAMKII, and MAP2 contain a dendritic localizer sequence (DLS) which targets the mRNA to the dendritic compartment (Blichenberg et al., 1999; Blichenberg et al., 2001; Mohr and Richter, 2004). An additional mechanism for controlling localization is through PDZ-containing anchoring proteins which target G-protein-gated K⁺ channels (Kir3.2c) to the postsynaptic density in dopaminergic neurons of the substantia nigra (Kurachi and Ishii, 2004). Lastly, β subunits of channels have also been proposed to play a role in localization. For instance, association of the auxiliary β subunit with the calcium channel α 1 subunit results in increased membrane localization (Bichet et al., 2000).

Compartment-specific ethanol effects on BK channels are determined by regional specificity of beta subunit

A strong correlation between BK β subunit identity and ethanol sensitivity has been shown in HEK293 expression studies (Feinberg-Zadek and Treistman, 2007) and freshly dissociated rat nucleus accumbens neurons (Martin et al., 2004). In medium spiny neurons the effects of EtOH on BK channels are regionally specific, similar to the HNS. Interestingly, in contrast to the HNS, medium spiny neuron cell body BK channels are sensitive to EtOH, while dendritic BK channels are insensitive to the drug. In these neurons, this dichotomy correlates with the differential distribution of $\beta 1$ and $\beta 4$ subunit to the dendrite and soma, respectively. Likewise, we suggest that the observed differences in ethanol sensitivity between HNS somatodendritic and nerve terminal channels reflect a differential distribution of $\beta 1$ and $\beta 4$ subunits.

A link between subunit composition and ethanol sensitivity has also been reported for other ion channels. For example, the effects of ethanol on P2X receptors are dependent upon receptor subtype, with P2X3 receptors potentiated and P2X4 receptors inhibited by EtOH (Davies et al., 2005). NMDA receptor NR2B subunits and NR1 splice variants are also thought to confer sensitivity to EtOH-induced inhibition of NMDA currents (Chu et al., 1995; Kalluri and Ticku, 1999; Peoples and Stewart, 2000; Smothers et al., 2001; Jin and Woodward, 2006; Kash et al., 2008). Furthermore, various AMPA and GABA receptor subtypes are also differentially sensitive to ethanol (Akinshola et al.,

2003;Borghese and Harris, 2007;Jia et al., 2007;Korpi et al., 2007;Mody et al., 2007;Olsen et al., 2007;Santhakumar et al., 2007).

While we propose that regional ethanol sensitivity within magnocellular neurons in the HNS is conferred through subunit composition several other factors may also play a role. These factors include variations in α subunit splice variants, regional differences in lipid bilayer composition and additional posttranslational modifications. For example, expression studies in HEK293 cells indicate that certain α isoforms such as STREX are alcohol insensitive (Pietrzykowski et al., 2008). In addition, bilayer studies have shown that modulation of the lipid environment can alter BK channel sensitivity to ethanol (Crowley et al., 2003;Crowley et al., 2005). Lastly, posttranslational modifications including phosphorylation status of BK channels have also been shown to alter ethanol sensitivity (Liu et al., 2006).

Functional implications

The selective regional distribution of alcohol sensitive and insensitive channels in the HNS has interesting implications for synaptic integration. The SON receives excitatory glutamatergic inputs from areas such as the amygdala, the suprachiasmatic nucleus, and the lamina terminalis (Csaki et al., 2002). In addition, the SON receives inhibitory GABAergic inputs from areas such as the nucleus accumbens, a region known to play a role in addiction (Shibuki, 1984;Li

et al., 2001). Both excitatory glutamatergic and inhibitory GABAergic inputs establish synaptic contact primarily on the dendrites of the SON, which generally comprise approximately 80% of the neuron's surface area. The selective distribution of alcohol insensitive channels to the dendritic compartment may suggest that the effects of alcohol on HNS neurons mediated through BK channels have little direct impact on the integration of dendritic electrical activity. Instead, the selective distribution of ethanol sensitive BK channels to the nerve terminal compartment suggests that the effect of alcohol on HNS neurons mediated through BK channels is largely confined to the nerve terminal.

In addition to the role that nerve terminal BK channels play in mediating HNS responses to ethanol, somatodendritic BK channels may also indirectly contribute to ethanol effects, despite their apparent insensitivity to the drug. This possibility exists because BK channels can form heteromultimeric complexes with both voltage-gated calcium channels and NMDA receptors (Marrion and Tavalin, 1998; Isaacson and Murphy, 2001). Ethanol inhibits voltage-gated calcium channels and NMDA receptors thereby lowering intracellular calcium levels (Nie et al., 1994; Widmer et al., 1998). As a result of BK channel activation by calcium, ethanol induced changes in intracellular dendritic calcium levels may be transduced by the associated BK channels, ultimately influencing input and output patterns of HNS neurons. Thus, the presence of BK channels in somatodendritic and nerve terminal compartments of HNS neurons, and their

corresponding differential sensitivity to ethanol, may play an important role in the response to ethanol.

Peptide hormone release

In the HNS, both somatodendritic and nerve terminal compartments secrete the peptides oxytocin (OXT) and vasopressin (AVP). The dendrites of magnocellular neurons release OXT and AVP centrally into the brain, while nerve terminals release OXT and AVP peripherally into systemic circulation. It is of particular interest that while both dendrites and nerve terminals secrete AVP and OXT, release from these two compartments can occur independently and is differentially regulated (reviewed in Ludwig and Leng, 2006). In terminals, peptide release is regulated in an activity dependent manner when membrane depolarization elicits calcium entry through voltage-gated calcium channels (Wang et al., 1999a; Wang et al., 1997). Dendritic release, on the other hand, is triggered not only by depolarization induced calcium entry, but also by the release of calcium from intracellular stores in response to the binding of AVP or OXT to its corresponding autoreceptor (Lambert et al., 1994; Dayanithi et al., 1996; Ludwig et al., 2005). Our study shows that these two compartments, the nerve terminal and dendrite, have distinctly different BK channels with varying calcium sensitivities, which may contribute to differences in the regulation of peptide release.

Acknowledgements: We thank Andy Wilson, Sonia Ortiz-Miranda, and José Lemos for their technical and critical advice. These studies were supported by funds from the NIAAA.

Chapter Two

**Persistence of Rapid Ethanol Tolerance of BK Channels
in Striatal Neurons is a Function of Exposure Time**

Abstract

BK channel activity is directly modulated by ethanol and plays a significant role in behavioral tolerance in invertebrates. We have previously shown, in hypothalamic neurons that BK channels develop acute tolerance to alcohol which occurs as a two-component process: 1) reduced potentiation to EtOH challenge which develops within a few minutes, and 2) a reduction in current density which develops over a time course of several hours. The nucleus accumbens (NAcc), a part of the striatum, is an important component of reward circuitry in the brain. Here, we use patch clamp techniques in cultured striatal neurons from P8 rats to examine another class of tolerance called rapid tolerance. We report that BK channels in these neurons also exhibit a two-component process of acute tolerance, and furthermore, discover that the duration of rapid tolerance is a function of exposure time. We found that persistence of rapid tolerance was surprisingly long. For example, after a 6 hr exposure to 20 mM ethanol, acute sensitivity was still suppressed at 24 hrs withdrawal. However, after a 1 or 3 hr exposure period, sensitivity had returned after only 4 hrs. We have also found that during withdrawal from a 6 hr but not a 3 hr exposure the biophysical properties of BK channels change and that this change is correlated with an increase in mRNA levels of the alcohol insensitive STREX splice variant. Furthermore, BK channel properties during withdrawal from a 6 hr exposure to alcohol closely parallel the properties of STREX channels exogenously

expressed in HEK293 cells. Thus, we have established that acute and rapid tolerance occur in these neurons, that rapid tolerance is dependent upon exposure protocol, and is surprisingly persistent. The persistence of rapid tolerance may be explained by an increase in the alcohol-insensitive BK channel splice variant, STREX. These findings may find relevance in explaining how short term exposure to alcohol impacts the development of alcohol dependence in humans.

Introduction

Alcohol addiction is a major socioeconomic and public health concern contributing to over one hundred thousand deaths annually. With more than 8 million Americans afflicted with alcoholism, it is the third leading cause of preventable mortality after smoking and diet/activity patterns (Mokdad et al., 2004). The progression to compulsive alcoholism is influenced by many factors such as increased craving, loss of control, and acquired tolerance. Neural adaptations underlying acquired tolerance are thought to contribute to the development of alcoholism by either permitting or causing increased levels of alcohol consumption. These adaptations mitigate the effects of alcohol such that higher and higher doses are required to produce the same response. Acquired alcohol tolerance has long been utilized as a predictor and diagnostic of alcoholism (Kalant, 1998).

Behaviorally, several classes of tolerance exist such as acute, rapid, and chronic tolerance. Acute tolerance refers to a decrease in impairment within a single session of alcohol exposure on the descending limb of the blood alcohol level (BAL) curve when the same BAL on the ascending limb produces noticeable impairment (LeBlanc et al., 1975). Rapid tolerance, on the other hand, refers to a reduced response to a second dose of alcohol administered 8-24 hrs after a first dose of alcohol (Bitran and Kalant, 1991). Lastly, chronic tolerance

describes reduced effects of alcohol after multiple drinking sessions preferably over a period of days or weeks (Khanna et al., 1996).

Interestingly, our lab has found a molecular correlate for behavioral tolerance. We have shown that large conductance calcium-activated potassium (BK) channels in the rat posterior pituitary also develop tolerance (Knott et al., 2002). These channels develop acute tolerance by first showing a reduction in potentiation which occurs within a few minutes of alcohol exposure. BK channels also develop a second component of tolerance in which there is a reduction in current density, that occurs after several hours of alcohol administration (Pietrzykowski et al., 2004). Behaviorally, BK channel activity plays a central role in the development of functional tolerance in invertebrates and mammals. Loss-of-function mutations in the BK channel gene of *D. melanogaster* effectively blocks the development of both acute and rapid tolerance suggesting that BK channels play a prominent role in mediating the response to alcohol (Ghezzi et al., 2004; Cowmeadow et al., 2005). Further, emphasizing the importance of BK channels in mediating tolerance, new studies reveal that BK $\beta 4$ knock-out mice develop tolerance to alcohol induced deficits in ambulatory activity whereas wild type mice do not (Martin et al., 2008).

However, there are many unanswered questions regarding the development of tolerance. One such question is whether the initiation of tolerance can be described by a “trigger function”, in which continued presence of the drug is unnecessary once the machinery of tolerance is initiated. It is also

unknown if there are temporally dependent “switches” tripped by drug exposure, which are associated with classes of channel tolerance. The aim of this study was to explore these ideas and determine if length of the initial alcohol exposure influences tolerance development.

Materials and Methods

Primary Striatal Culture

Cultures of dissociated rat striatal neurons were prepared using a modification of a previously described protocol (Leveque et al., 2000). Briefly, postnatal day eight Sprague-Dawley rat pups were decapitated, pup brains removed and immersed in ice-cold PBS. Next, striata were dissected, transferred to Hanks Balanced Salt Solution (Gibco, Grand Island, NY) with 10 mM HEPES, and dissociated using a fire-polished Pasteur pipette. Dissociated cells were transferred to the plating medium (a 1:1 mix of F12 nutrient mixture (Gibco) and DMEM medium supplemented with GlutaMAX; 2.0 mM glutamine final concentration), 2% fetal bovine serum (Hyclone), 2% B-27 (Gibco), 1% penicillin/streptomycin (Gibco). Cells in the plating medium were seeded out onto 35 mm Petri dishes (Nunc, Rochester, NY) coated successively with 0.01% (w/v) poly-L-ornithine (Sigma, St. Louis, MO) and 33 µg/ml mouse laminin (Invitrogen, Carlsbad, CA). 24 hours after plating, the plating medium was replaced with serum-free medium supplemented with 2% B-27, 2.0 mM glutamine and 1% penicillin/streptomycin. Thereafter, the medium was replaced every 3 to 4 days. Neuronal cultures were maintained in a 5% CO₂, humidified incubator (99% relative humidity) at 37°C. All experiments were performed on neurons that were 14-21 days in culture.

For initial alcohol exposures culture media was replaced with media containing 20 mM EtOH and incubated for 1, 3, or 6 hrs. For withdrawal periods, the dishes were washed 4 times with ethanol free media. Alcohol concentrations in the media at the end of the 1, 3, or 6 hr exposure and after washing were checked using a GM7Analyser (Analox Instruments Inc., MA). Control dishes received media changes at the same time as the ethanol exposed dishes. Media changes did not have an effect on ethanol sensitivity of the channel (data not shown). For electrophysiological experiments medium spiny neurons were identified by morphology (small to medium cell bodies and multiple thin processes) (Meredith et al., 1992;Meredith et al., 1995).

Hek Cell Transfection

Cells from the Human Embryonic Kidney cell line (HEK293 cells) were cultured in DMEM medium supplemented with 10% heat-inactivated fetal bovine serum, 1 % penicillin/streptomycin, and 25 mM HEPES (Invitrogen), and plated onto 25 cm² flasks. The cells were maintained in a 5% CO₂, humidified incubator (99% relative humidity) at 37°C. Prior to transfection HEK293 cells were split from confluent cultures and plated on 60 mm Petri dishes. For all experiments 50-70% confluent cells were transfected using PolyFect transfection reagent (Qiagen,Balencia, CA) complexed with BK α variant (BK-Insertless, BK-P27, BK-STREX) and BK- β 4 subunit (when required) cDNAs in pVAX vector (Invitrogen) together with the expression plasmid (π H3-CD-8) encoding the α subunit of the

human CD-8 lymphocyte surface antigen (GeneBank M12824). To identify transfected cells, CD-8 antibody-coated beads were used (Dyna/Invitrogen). Prior to electrophysiological recordings, 0.5 $\mu\text{L}/\text{mL}$ of the CD-8 antibody coated beads were added to each culture dish for 30 min. Unattached beads were washed out with regular Locke's solution and recordings obtained from clearly identified cells with attached beads.

Electrophysiological Recordings

Recording electrodes were pulled on a horizontal puller (Sutter Instruments, Novato, CA), coated with Sylgard (Dow Corning Co., Broomall, PA), and fire-polished from borosilicate thin-wall capillary glass (Drummond, Broomall, PA) to a final resistance of 4-8 $\text{M}\Omega$. Currents were recorded in voltage-clamp mode with a HEKA EPC 10 amplifier at a sampling rate of 5 kHz and 10 kHz for whole cell and single channel recordings respectively, and low-pass filtered at 3 and 2 kHz, respectively. Leak currents were subtracted on-line using a conventional P/n (4) protocol. In whole-cell mode, series resistance did not exceed 20 $\text{M}\Omega$ and was 60% compensated. Potentials and currents were digitized and stored using Patchmaster acquisition and analysis software version 2.05 (HEKA Elektronik, Lambrecht/Pfalz, Germany).

Single Channel recordings

Typical cell-attached patch clamp mode was used to assess ethanol sensitivity of single channels in order to maintain the intracellular milieu and secondary signaling pathways during recording. Control (no alcohol) and 50 mM ethanol-containing solutions were enclosed in 50 ml syringes and expelled from hematocrite tubes. Each cell was its own control. To determine baseline activity (defined here as open probability – NP_o) before alcohol application, BK channel activity was recorded 3 times, 20 sec each, with 1 min intervals. For alcohol perfusion, the ethanol containing hemacrite tube was positioned close to the cell. Then, 50 mM alcohol was applied and BK channel activity recorded in successive blocks of 20 sec at 1 min intervals for up to 10 min. Control experiments were performed by perfusing patches with an ethanol-free solution for up to 15 minutes. In control experiments there was no a significant deviation in baseline channel activity throughout the 15 minute time period (data not shown).

Cell-attached patch clamp mode was also used for mean open/closed times. In these experiments, BK channel activity was recorded 3 times, 20 sec each, with 1 min intervals. For all cell-attached experiments, the voltages given represent the potential at the intracellular side of the membrane.

To determine whether BK channels were present in the membrane of cultured striatal neurons we recorded single channels in the inside-out and outside-out

patch clamp configuration, respectively. We recorded in these configurations to precisely control the free intracellular calcium concentration to which BK channels were exposed. For all experiments, voltages given correspond to the potential at the intracellular side of the membrane.

To measure the activation rate of channels in striatal culture, macroscopic currents were compiled by summing 100 consecutive single channel traces obtained by stepping the membrane of an outside-out patch from a holding potential of -60 mV to a potential eliciting an NPo of approximately 0.5, between +30 and +60mV, in the presence of 10 μM free- Ca^{2+} (in the recording pipette). Leak currents were subtracted on-line using the P/n (4) protocol. To yield the macroscopic current, traces were summed and the activation kinetics fit using Fitmaster software (HEKA Elektronik, Lambrecht/Pfalz, Germany). The activation rate (ms) versus voltage was plotted and linearly fit. The slope of the linear fit was used as the measure of voltage dependence.

Whole-cell recordings

Using the standard whole-cell patch clamp recording method (Hamill et al., 1981) from a holding potential of -60 mV, the membrane potential was depolarized to various potentials for 500 ms. Mean BK current amplitude was measured at BK current steady state, 450-490 ms after the beginning of the voltage step. The recording pipette routinely included in mM: 0.1 leupeptin, 12 phosphocreatine, 2

K-ATP, and 0.2 Na-GTP to prevent run-down of the Ca^{2+} current (Kittler et al., 2005; Hainsworth et al., 2006). The inclusion of leupeptin serves to block proteases while phosphocreatine and K-ATP allow the regeneration of ATP. When applying pharmacological agents such as 4-aminopyridine (4-AP), iberiotoxin (Ibtx), tetraethylammonium-chloride (TEA-CL), and 8-bromo-cAMP hemacrite tubes containing the appropriate solution were juxtaposed to the cell.

Data analysis

Data were analyzed using Tac X4.1.5 and TacFit X4.1.5 software (Bruxon, Seattle, WA). NP_o values were calculated from all-points amplitude histograms by fitting the histogram with a sum of Gaussian functions using a Levenberg–Marquardt algorithm. Values for unitary current were obtained from the Gaussian fit of all-points amplitude histograms by measuring the distance between the modes corresponding to the closed state and the first opening level. The unitary conductance (γ) was taken as the slope of the unitary current amplitude–voltage relationship. In single channel patches, durations of open and closed times were measured with half-amplitude threshold analysis. A maximum-likelihood minimization routine was used to fit curves to the distribution of open and closed times. Determination of the minimum number of terms for adequate fit was established using a standard F statistic table (significance level, $P < 0.01$). To compute G/G_{max} a series of macroscopic currents were obtained in the presence of 1 mM 4-AP to block I_A current. Current traces were evoked from a

holding potential of -60 mV to +180 mV or +360 mV in 20 mV increments with 1 or 10 μM free- Ca^{2+} in the recording pipette, respectively. The conductance (G) is the mean amplitude taken from the sustained portion of the macroscopic current, 450-490 ms after the beginning of the voltage step. G_{max} is the mean amplitude taken at the minimum voltage that elicits maximal current.

Depolarizing steps greater than the minimum voltage do not elicit a significant amount of additional current. To calculate current density (pA/pF) in striatal neurons current amplitude was obtained from the sustained component of the macroscopic potassium current. Macroscopic currents were evoked by stepping from a holding potential of -60 mV to +60 mV in Regular Locke's solution.

Membrane capacitance (pF) was automatically calculated in the HEKA patchmaster software.

Experimental Solutions

Regular Locke's solution contained the following (in mM): 2 KCl, 142 NaCl, 2 MgCl_2 , 2 CaCl_2 , 13 glucose, and 15 HEPES. High potassium pipette solution contained (in mM): 135-140 K-gluconate, 0-4 HEDTA, 0-4 EGTA, 15 HEPES, 1 MgCl_2 , and 0.5-2.2 CaCl_2 . HEDTA, EGTA, and CaCl_2 concentrations were adjusted to obtain the desired concentrations of free calcium, ranging from 1 to 10 μM free- Ca^{2+} . Free- Ca^{2+} concentrations were determined by the Sliders software and confirmed with a Kwik-Tip calcium probe (World Precision Instruments, Sarasota, FL).

Chemicals

Ethanol, HEPES, and $MgCl_2$ were obtained from American Bioanalytical (Natick, MA). $BaCl_2$ and $CaCl_2$ were from Fisher Scientific (Fair Lawn, NJ). Potassium gluconate, glucose, HEDTA, EGTA, TEA-chloride, 4-aminopyridine (4-AP), iberiotoxin, 8-bromo-cAMP, leupeptin, phosphocreatine, K-ATP, and Na-GTP were obtained from Sigma-Aldrich Chemical (St. Louis, MO). NaCl and KCl were from EM Science (Gibbstown, NJ).

Reverse transcription-PCR

Total RNA was isolated from the striatal culture dishes with Trizol (Invitrogen, Carlsbad, CA). Manufacturer's instructions were followed for RNA isolation using an RNeasy Protect Mini extraction kit (Qiagen, Valencia, CA) and Glycol Blue (Ambion, Austin, TX) to aid in the visualization of RNA precipitate. RNA quality (A260/280) and concentration was determined by a ND-1000 Spectrophotometer (NanoDrop, Wilmington, DE). After extraction, total RNA aliquots were treated with 20 U of RQ1 RNase-Free DNase (Promega, Madison, WI) for 15 min at 37°C to minimize the risk of genomic DNA contamination. First strand cDNA was reverse transcribed from the DNase-treated aliquots using the iScript cDNA Synthesis Kit (BioRad, Hercules, CA) and stored at -20°C.

FAM-based Real-time PCR was used to quantify expression changes of BK B1 and STREX mRNA in treated striatal cultures compared to control cultures and were performed in triplicate. β -actin mRNA is unaffected by acute and chronic alcohol exposure in neuronal tissue and was used as an endogenous control to accurately calculate mRNA expression (Nakahara et al., 2002; Newton et al., 2005). No-reverse transcriptase (No RT) and no-template controls were routinely included. The following pairs of primers were used: KCNMB1, ATCAAGGACCAGGAAGAGCTG (5' primer) and CTACTIONCTGAGCTGCCAAGAC (3' primer); and STREX AGGCGGCCCAAGATGT (5' primer) and ATGCACGAGCAGTCACGCTCA (3' primer). All amplicons (the primers and probes) were checked for lack of secondary structure formation ensuring optimal PCR efficiency (IDT BioTools). Probes were synthesized to have their 5' end labeled with in a 25 μ L final volume, using Real Time Master Mix Probe with ROX (Eppendorf, Westbury, NY), on an ABI Prism 7500 PCR System (Applied Biosystems). The reverse-transcription reactions were performed at 42°C for 45 min, followed by 35 cycles of PCR amplification (15 sec at 94°C, 30 sec at 56°C, 15 sec at 72°C). To verify that the signals detected were not caused by genomic DNA contamination, RT-PCRs were also performed for each pair of primers without reverse transcriptase. Significance was determined using one-way ANOVA.

Immunocytochemistry

Primary striatal neurons were cultured on glass bottom culture dishes (MatTek, Ashland, MA) and fixed in 4% paraformaldehyde (PFA). Cultured neurons were then blocked in buffer containing 10% NGS, 0.1% BSA, in PBS/0.02% sodium azide, pH 7.4, for 1 hr at room temperature. Non-permeabilized striatal neurons were incubated (overnight at 4°C) with a specific monoclonal primary antibody (1:100, clone L18A/3, NeuroMab, UC Davis, CA) targeting the extracellular domain of the BK β 4 channel subunit. This antibody was generated using an immunogen comprising amino acids 45-167 (entire extracellular domain) of mouse BK- β 4 (accession number NP_067427). This antibody does not cross-react with BK- β 1, β 2, or β 3.

After non-permeabilized cells were incubated with anti- β 4 antibody the culture dishes were rinsed, and incubated for 1 hr at room temperature with Alexa 594-tagged, anti-mouse secondary antibody (1:300; Molecular Probes, Eugene, OR). Next, sections were permeabilized with a 0.4% Triton-X solution and incubated with 1:100 anti- glutamate decarboxylase (GAD67), a GABAergic neuronal marker (Chemicon, Temecula CA; 2 hrs at room temperature) (Varea et al., 2007). After incubation culture dishes were rinsed and incubated for 1 hr at room temperature with Alexa 488-tagged anti-mouse secondary antibody (1:300; Molecular Probes, Eugene, OR). Finally, cultures were co-stained with DAPI (1:50,000; Sigma, St. Louis, MO), a fluorescent stain that binds DNA, for 5 min

and thoroughly rinsed with PBS. Coverslips were then mounted using Prolong Gold Antifade medium (Invitrogen, Carlsbad, CA) and stored at 4°C. This experiment was repeated with striatal neurons that were permeabilized during the first blocking step. To ensure that the anti-BK β 4 antibody detected the extracellular domain of the protein we expressed BK $\alpha\beta$ 4 channels in HEK293 cells and incubated either permeabilized or non-permeabilized cells (Appendix A). A Zeiss Axiovert inverted microscope and Axiovision 4.5 software package (Carl Zeiss, Inc., Thornwood, NY) were used to acquire Z-stacks of fluorescent images, deconvolve, and perform subsequent analysis.

Results

Cultured striatal neurons express functional BK channels

Previous studies reported the presence of BK channels in adult striatal neurons (Martin et al., 2004). To insure that, like adult striatal neurons, cultured striatal neurons also expressed functional BK channels we assessed the basic electrophysiological properties of single BK channels, including voltage sensitivity and conductance, in inside-out patches. Striatal single channel currents were elicited by depolarizing the membrane from -80 mV to +80 mV in 20 mV increments while perfusing the intracellular surface with 10 μ M free- Ca^{2+} . Striatal neurons were morphologically distinguished from glial cells and interneurons present in the culture (see Materials and Methods). The activity of a single channel patch recorded between -60 mV and +40 mV is shown in Figure 1B. At -60 mV, the channel displays a low open probability ($\text{NPo} = 0.104$) but as the channel membrane is depolarized to +40 mV the channel spends more time in the open state ($\text{NPo} = 0.956$). Figure 1C shows a plot of the current amplitude vs. the membrane potential of a striatal channel. The current-voltage relationship was well-fitted with a linear regression ($r = 0.99$) yielding a slope conductance of 230 pS. In addition, current reversed at 0 mV in symmetric potassium conditions, $[\text{K}]_i = [\text{K}]_o$, indicating the channels are selective for potassium.

To determine the relative contribution of BK current to the total macroscopic current in striatal neurons we pharmacologically dissociated the K^+ current using

well known toxins. Conventional whole-cell recordings of macroscopic K⁺ currents were evoked by stepping from a holding potential of -60 mV to +80 mV. In Figure 1D, the upper trace is the total macroscopic K⁺ current, recorded in normal Locke's solution containing 2.2 mM calcium. Addition of the I_A channel inhibitor 4-AP (1 mM) removes the fast inactivating I_A and indicates that 43 ± 5% of the total current is due to I_A. After blockade of I_A a combined non-inactivating BK current and a resistant current remains (second highest trace). Perfusion with 100 nM Iberitoxin (Ibtx) specifically blocks BK channels leaving a 4-AP and Ibtx resistant current. Blockade with Ibtx indicates that BK channel contribute to 27 ± 7% of the total K⁺ current. Finally, addition of 100 mM TEA-chloride, a blocker of voltage-dependent potassium channels, indicates that of the total K⁺ current, 25 ± 3% is comprised of TEA sensitive current. Taken together these data are consistent with the known features of BK channels including potassium selectivity, large conductance (>180 pS), and sensitivity to iberitoxin (McManus, 1991; Lippiat et al., 2003).

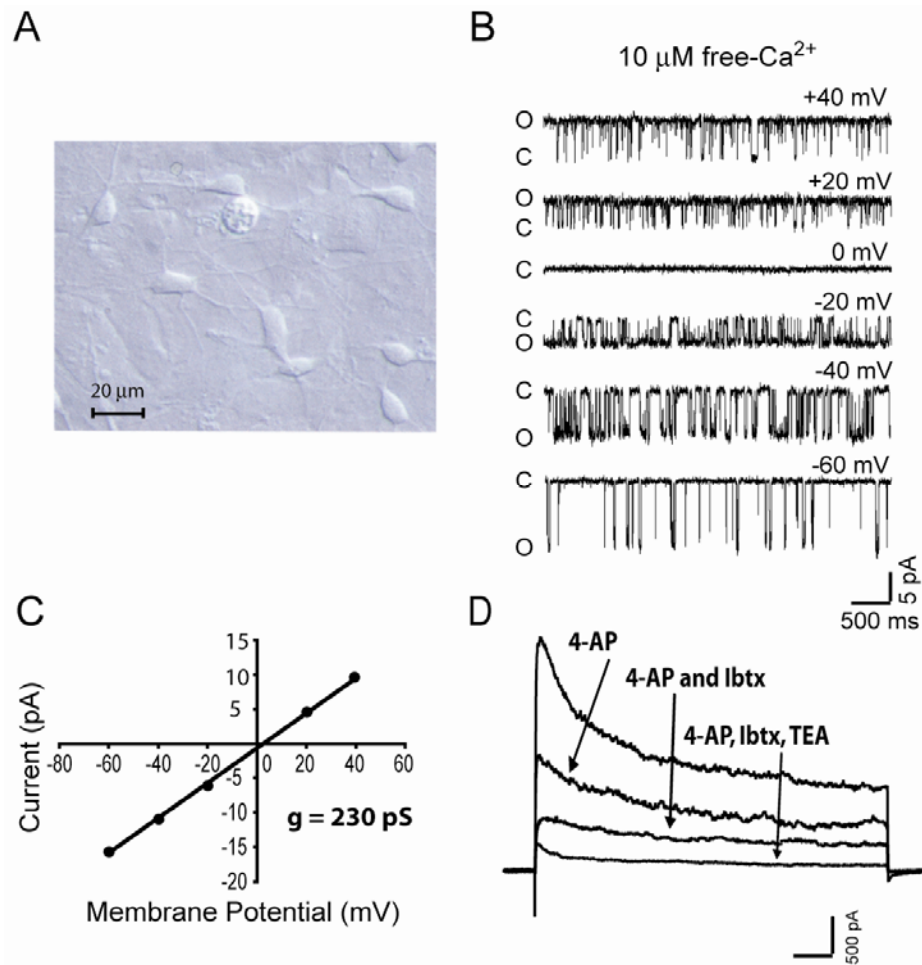

Figure 1. Conductance, voltage dependence, and pharmacology of BK channels in cultured striatal neurons. (A) Digitally captured image of rat P8 striatal neurons one week in culture. (B) The time spent in the open state by one striatal BK channel, recorded in the inside-out patch clamp configuration in the presence of $10 \mu\text{M}$ free- Ca^{2+} , increases as the membrane is depolarized. C and O represent the closed and open states, respectively. (C) Plot of BK channel current amplitude as a function of membrane potential. A linear fit of this relationship ($r = 0.99$) gave a BK channel unitary conductance of 230 pS . (D) Pharmacological dissociation of the macroscopic potassium current in striatal neurons. Macroscopic currents were evoked by stepping from a holding potential of -60 mV to $+80 \text{ mV}$. The upper trace is the total current, recorded in normal

Locke's solution containing 2.2 mM calcium. Addition of the I_A channel inhibitor 4-AP (1 mM) removes the fast inactivating I_A , leaving a combined non-inactivating BK current and a resistant current (second highest trace). Perfusion with 100 nM Ibtx specifically blocks BK channels leaving a 4-AP and Ibtx resistant current. Finally, addition of 100 mM TEA-chloride, a blocker of voltage-dependent potassium channels, leaves a resistant current (lower trace). In subsequent figures, I_A is subtracted from the macroscopic current by inclusion of 1 mM 4-AP.

BK channels in striatal neurons are ethanol sensitive and develop acute tolerance

Our lab has reported that BK channels in freshly dissociated NAcc cell bodies are ethanol sensitive (Martin et al., 2004). We have also previously shown, in hypothalamic neurons, that BK channels develop two components of acute alcohol tolerance (Pietrzykowski et al., 2004). Similarly, in this study we have discovered that BK channels in cultured striatal neurons develop two components of acute tolerance to 50 mM EtOH, first there is a reduction in potentiation which occurs within a few minutes of exposure and second there a reduction in current density which occurs after several hours of alcohol (see Figure 1A, Appendix A and Figure 9).

To begin to examine the phenomenon of rapid tolerance we had to determine which durations of alcohol exposure we would test. Data from functional tolerance studies had shown that blood alcohol levels after a single IP injection of 1.0, 1.5, or 2.0 g/kg EtOH decline to undetectable amounts after 3-6 hr (Schulteis and Liu, 2006). Therefore, to determine whether duration of rapid tolerance is a function of initial alcohol exposure length we recorded BK channel activity (NPo) before and after exposure to 50 mM EtOH in a cell-attached patch from striatal neurons pre-exposed to 20 mM EtOH for 1, 3, or 6 hrs followed by various withdrawal periods. In all patches tested, acute application of 50 mM EtOH immediately following pre-exposure to 20 mM EtOH for 1, 3, or 6 hr did not

change baseline channel activity indicating that the channels are tolerant to the second dose of alcohol (data not shown).

In Figure 2A, baseline BK channel activity was recorded at a holding potential of -60 mV immediately following exposure to 20 mM EtOH for 3 hr and 4 hr withdrawal (NPo = 0.09). Acute challenge with 50 mM EtOH potentiated channel activity (NPo = .26) indicating that 4 hrs is sufficient to recover from a 3 hr alcohol exposure. Likewise, 4 hrs in ethanol free conditions was sufficient to recover from a 1 hr exposure to 20 mM EtOH (Figure 2D). However, as shown in Figure 2D neurons which were pre-exposed to 20 mM EtOH for 6 hr did not recover at the 4 hr withdrawal timepoint (n-fold increase in potentiation was 1.052 ± 0.033 , n = 8). Furthermore, the persistence of rapid tolerance was surprisingly long with sensitivity still suppressed at 24 hrs withdrawal (n-fold increase in potentiation was 0.997 ± 0.021 , n = 7).

Thus, we have established that indeed there is a “switch” triggered during a 6 hr EtOH exposure that does not occur during a 3 hr exposure resulting in persistent insensitivity to the drug. The data also show that continued exposure to EtOH is not necessary for the maintenance of tolerance after a 3 or 6 hr exposure but that duration of tolerance is dependent on the length of initial alcohol exposure.

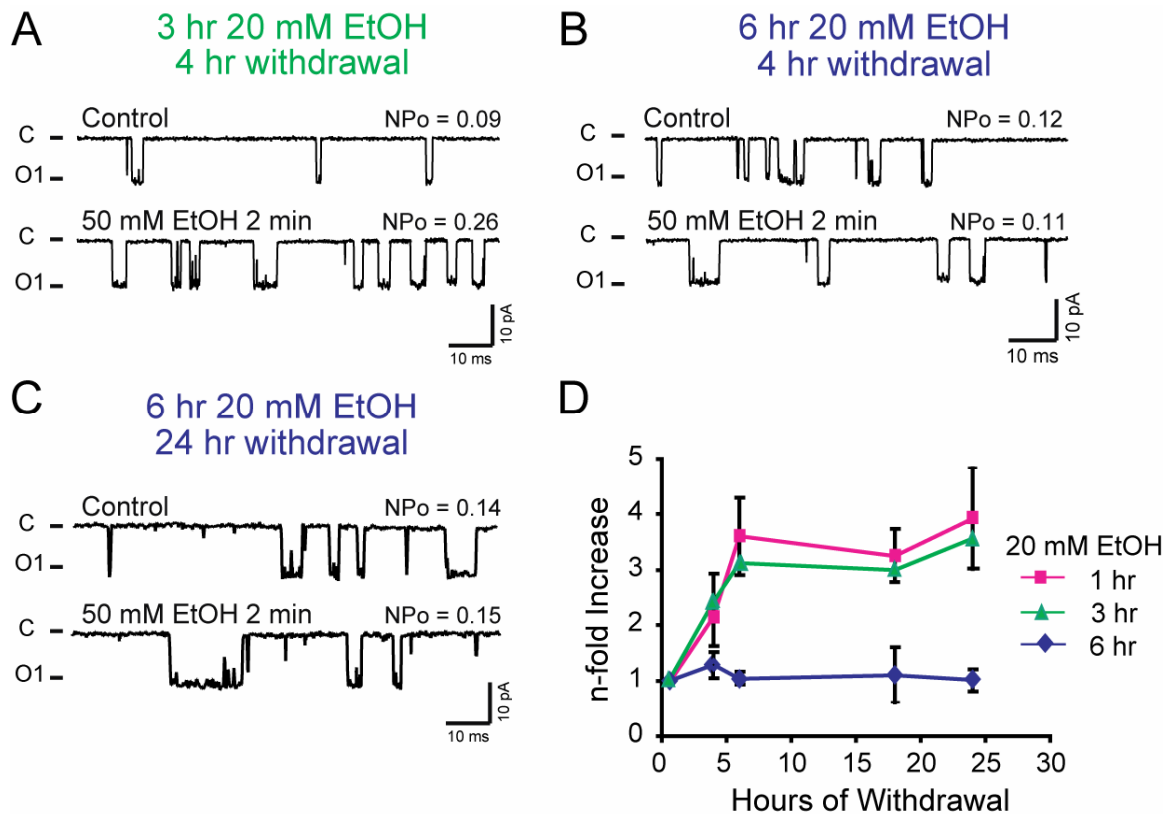

Figure 2. Persistence of rapid tolerance is a function of ethanol exposure time. BK channel activity (NP_o) before and after exposure to 50 mM EtOH in a cell-attached patch from striatal neurons which were (A) pre-exposed to 20 mM EtOH for 3 hr and ethanol withdrawn for 4 hr, (B) pre-exposed to 20 mM EtOH for 6 hr and ethanol withdrawn for 4 hr, or (C) pre-exposed to 20 mM EtOH for 6 hr and ethanol withdrawn for 24 hr. All traces were recorded at a holding potential of -60 mV. C and O represent the closed and open state, respectively. (D) Scatter plot of the n-fold increase in BK channel activity after exposure to 50 mM EtOH in striatal neurons pre-exposed to 20 mM EtOH for 1, 3, or 6 hr (pink, green, and blue, respectively) followed by various periods of withdrawal.

There are numerous underlying mechanisms which could account for the persistent insensitivity to alcohol observed after 6 hr EtOH treatment. These channels may have undergone (1) transcriptional changes including changes in subunit composition, (2) post-translational modifications including modulation by kinases and phosphatases, and even environmental changes like (3) lipid alterations. To begin to unravel the potential mechanism underlying rapid tolerance we wanted to explore whether the biophysical properties of BK channels were different during withdrawal from a 6 versus 3 hr exposure to EtOH. To do so, we characterized the calcium sensitivity, activation rate, and mean open and closed time of BK channel currents.

There is a shift in BK channel calcium sensitivity after a 6 but not a 3 hr exposure to EtOH.

BK channels are present in approximately 10% of the striatal neuron patches, presumably because BK channels have such a high conductance that they are not necessary in large quantities to have a pronounced effect on excitability.

Therefore, to quickly gauge whether there was a change in calcium sensitivity of the BK current we examined the conductance-voltage (G-V) relationship of macroscopic currents by measuring G/G_{\max} . To compute G/G_{\max} a series of macroscopic currents were obtained in the presence of 1 mM 4-AP to block I_A current. Current traces were evoked from a holding potential of -60 mV to +360 mV in 20 mV increments with 1 μ M free- Ca^{2+} in the recording pipette (Figure 3,

first column). We found that there was a leftward shift in the G-V relationship present during withdrawal after a 6 hr but not 3 hr exposure to 20 mM EtOH, however, the voltage steps required to elicit G_{\max} were well outside of physiological range.

Therefore, in order to determine whether there was also a leftward shift in the G-V relationship during withdrawal from a 6 hr EtOH but not 3 hr EtOH in more physiologically relevant voltage ranges we evoked a series of macroscopic currents by stepping from a holding potential of -60 mV to +180 mV in 20 mV increments with 10 μM free- Ca^{2+} in the recording pipette (Figure 3, second column). We chose 10 μM free- Ca^{2+} because it has been shown in rat chromaffin cells that BK channels are subjected to a wide range of intracellular calcium, the average of which is approximately 10 μM (Prakriya et al., 1996). Indeed we also observed a leftward shift in the G-V relationship within this physiologically relevant calcium and voltage range during withdrawal from 6 but not 3 hr EtOH.

To confirm that the shift in the G-V relationship was due to a change in the BK channel current and not other contaminating currents present in cultured striatal neurons we blocked BK current with 100 nM Ibtx. This concentration of Ibtx had been shown previously to specifically and effectively block BK currents (Hanner et al., 1998; Meera et al., 2000; Behrens et al., 2000; Lippiat et al., 2003). Traces

in the third column were evoked by stepping from a holding potential of -60 mV to +360 mV in 20 mV increments with 10 μM free- Ca^{2+} in the recording pipette and 100 nM Ibtx in the bath (Figure 3, column 3). Using Ibtx we were able to block the shift in the G-V relationship we previously observed after 6 hr EtOH indicating the shift is mostly due to changes in the BK current. Furthermore, this shift most likely reflects a change in the calcium sensitivity of BK current.

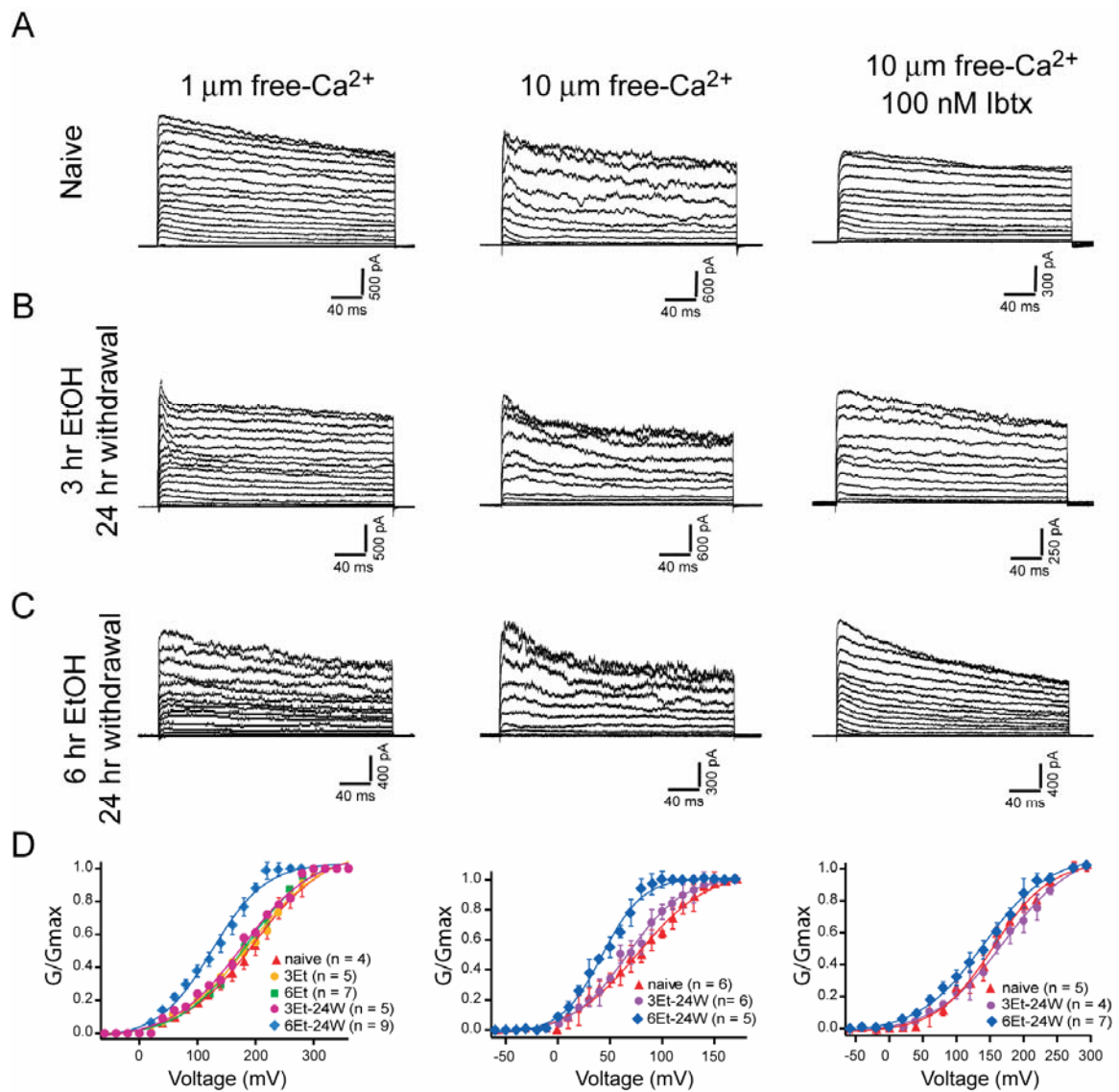

Figure 3. BK channels contribute to the leftward shift in G-V relationship present during withdrawal after a 6 hr but not 3 hr exposure to 20 mM EtOH. (A) Representative current traces from striatal neurons which were (A) naive, (B) pre-exposed to 20 mM EtOH for 3 hr and ethanol withdrawn for 24 hr, or (C) pre-exposed to 20 mM EtOH for 6 hr and ethanol withdrawn for 24 hr. The traces in the first column were evoked by stepping from a holding potential of -60

mV to +360 mV in 20 mV increments with 1 μM free- Ca^{2+} in the recording pipette. Traces in the second column were evoked from a holding potential of -60 mV and stepped to +180 mV in 20 mV increments with 10 μM free- Ca^{2+} in the recording pipette. Traces in the third column were evoked by stepping from a holding potential of -60 mV to +360 mV in 20 mV increments with 10 μM free- Ca^{2+} in the recording pipette and 100 nM Ibtx in the bath. All macroscopic currents were obtained in Locke's solution with 1 mM 4-AP to block I_A current. (D) Plot of G-V relationship for macroscopic currents in A-C. Current was measured from the steady state of the macroscopic current, 450-490 ms after the beginning of the voltage step.

Gating kinetics of BK channels are different during withdrawal from 6 hr but not 3 hr alcohol

Although whole-cell patch clamp is generally used to study kinetic properties such as activation, we could not use this approach, because it would not have enabled us to independently examine BK channel properties without other contaminating K⁺ currents. Therefore, to study channel kinetics we compiled a cumulative current trace from the summation of 100 repetitively evoked single channel sweeps. The resulting current trace resembles the classical macroscopic current recorded in the whole-cell patch clamp configuration. The membrane of an outside-out patch was stepped, in the presence of 10 μM free-Ca²⁺, from a holding potential of -60 mV to a voltage at which the probability of the channel in the open state was approximately one half, NPo \sim 0.5, between +30 and +60 mV. A typical example showing 6 of 100 consecutive traces from channels which were naïve, pre-exposed for 3 hr to 20 mM EtOH and ethanol withdrawn for 24 hr, or pre-exposed to 6 hr 20 mM EtOH and ethanol withdrawn for 24 hr is shown in Figures 4A-C. An example of the compiled macroscopic current from these same patches is shown in Figures 4D-F. All of the activation rates were fit with a single exponential, τ was 2.70 ± 0.25 ms ($n = 3$) for naïve channels, 2.34 ± 0.33 ms ($n = 3$) for channels pre-exposed to 3 hr EtOH and withdrawn for 24 hr, and 19.15 ± 3.12 ms ($n = 3$) for channels pre-exposed to EtOH for 6 hr and withdrawn for 24 hr. Although activation rate is also voltage dependent, we found that the voltage dependence (see Materials

and Methods) of naïve, 3 hr EtOH and 24 hr withdrawn, and 6 hr EtOH and 24 hr withdrawn channels was very similar across the voltage range tested 30 – 60 mV (data not shown). Therefore, we conclude that the activation rate is significantly slower in the patches from neurons in withdrawal from 6 hr EtOH than those recovering from 3 hr alcohol exposure ($p < 0.01$, Student's t-test) indicating these channels are markedly different.

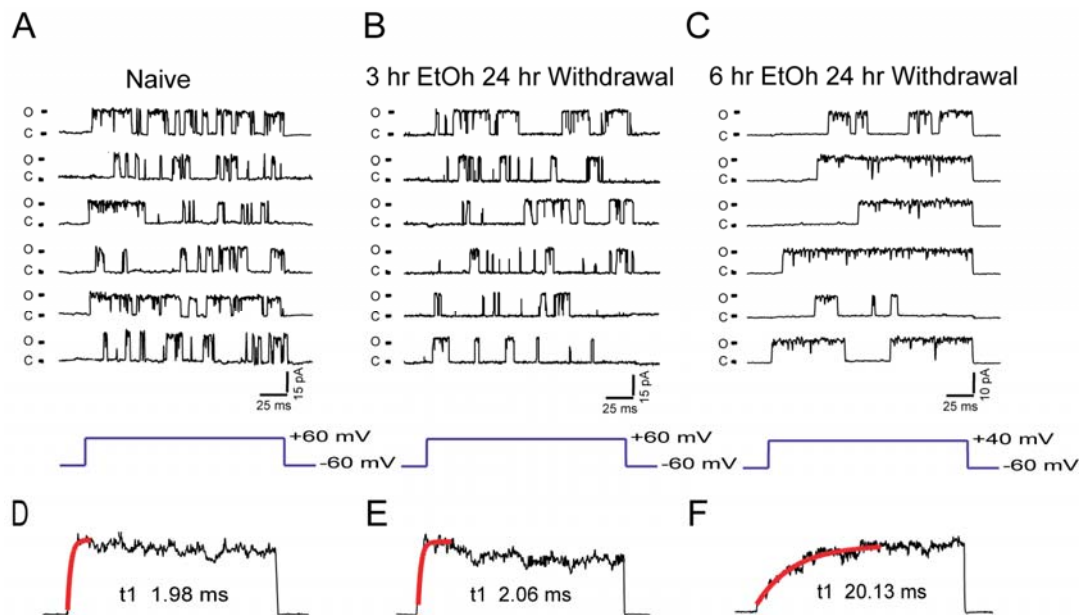

Figure 4. Gating properties of BK channels differ during withdrawal after a 6 hr but not a 3 hr exposure to 20 mM EtOH. A series of six consecutive BK traces evoked by depolarizing channels that were (A) naïve, (B) pre-exposed to 20 mM EtOH for 3 hr and ethanol withdrawn for 24 hr, or (C) pre-exposed to 20 mM EtOH for 6 hr and ethanol withdrawn for 24 hr. Channel activity was recorded in an outside-out patch with 10 μM free- Ca^{2+} in the recording electrode. Averaged current accumulated from 100 traces obtained from A-C. Current activation was best fit with a single exponential (see Materials and Methods).

To further explore the difference between channels in withdrawal from 3 or 6 hr EtOH we examined the mean open and closed times of single channels in cell-attached patch clamp mode. Representative traces of single BK channels that were naïve, pre-exposed to 20 mM EtOH for 3 hr and ethanol withdrawn for 24 hr, or pre-exposed to 20 mM EtOH for 6 hr and ethanol withdrawn for 24 hr are shown in Figure 5A-C. Channel activity was evoked by stepping from a holding potential of -60 mV to a potential of +70 mV for the traces recorded in panels A and B or +50 mV for the traces recorded in panel C to again yield a channel activity level of approximately one half, $N_{Po} \sim 0.5$. The dwell time distribution of single channel patches are shown in the histograms below the current traces. All of the open times distribution could be well fitted with a single component function, with $\tau = 9.13 \pm 1.95$ ms ($n = 4$), 7.86 ± 0.82 ms ($n = 4$), and 21.49 ± 3.76 ms ($n = 3$) for naïve, 3 hr EtOH/24 hr withdrawn, and 6 hr EtOH/24 hr withdrawn channels. Channels present during withdrawal from 6 hr EtOH had significantly slower mean open times than either naïve channels or channels present during withdrawal from 3 hr EtOH ($p < 0.05$, Student's t-test).

In contrast to the open times distribution, the closed times distribution was well fitted with a function of two components, with $\tau_{fast} = 6.71 \pm 1.89$ ms and $\tau_{slow} = 60.80 \pm 9.32$ ms for naïve channels, $\tau_{fast} = 5.52 \pm 1.14$ ms and $\tau_{slow} = 53.44 \pm 4.37$ ms for channels in withdrawal for 24 hr from 3 hr EtOH, and $\tau_{fast} = 70.26 \pm 10.84$ ms and $\tau_{slow} = 230.33 \pm 31.49$ for channels in withdrawal for 24 hr from 6 hr

EtOH. These biophysical properties are summarized in Table 1 and indicate that BK channels present during withdrawal from 6 hr but not 3 hr EtOH are (1) more sensitive to calcium (indicated as a shift in $V_{1/2}$ to more hyperpolarized potentials), (2) have a slower activation rate, and (3) have much slower open and closed times.

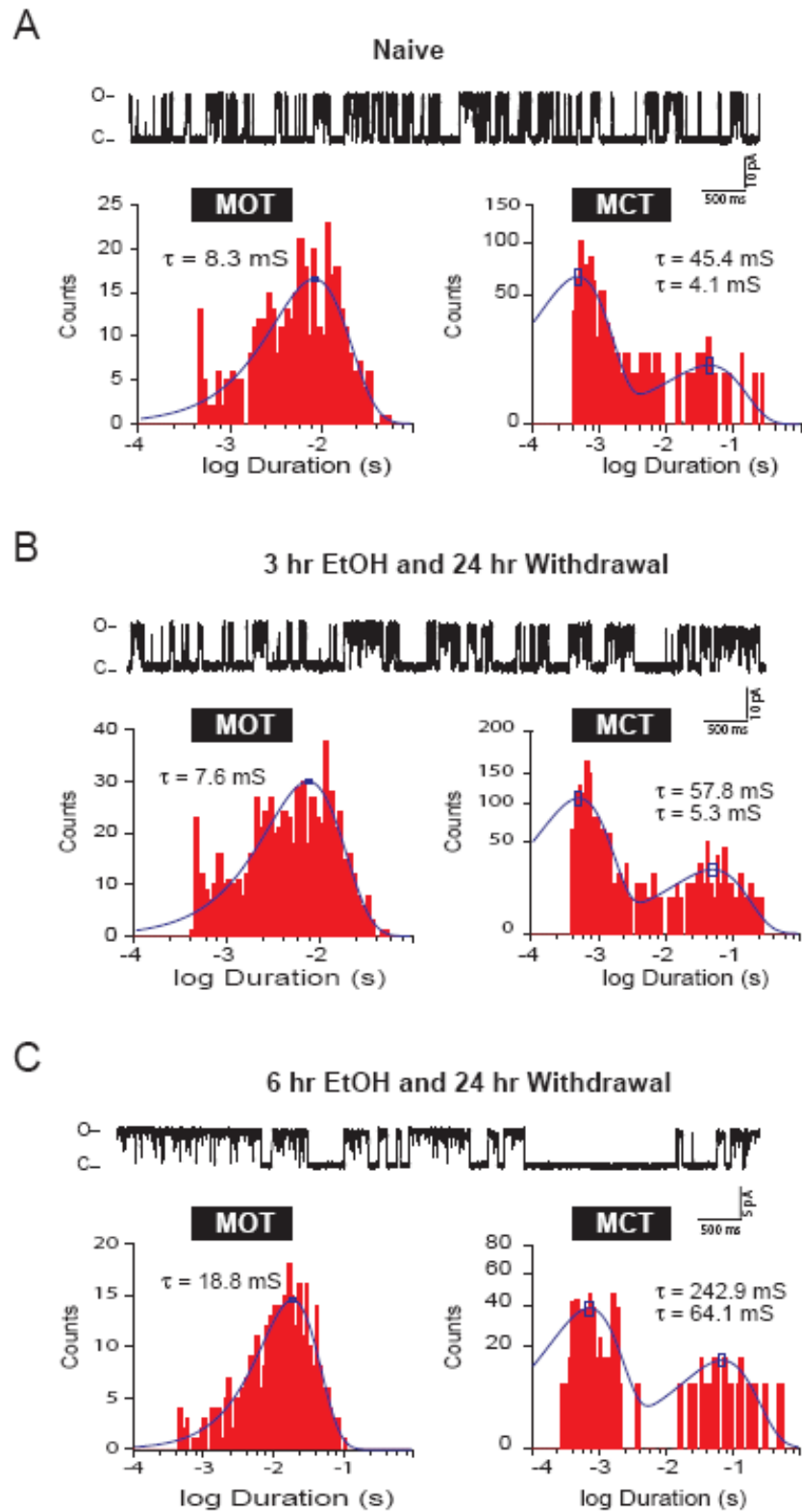

Figure 5. Mean open (MOT) and closed times (MCT) of BK channels are different during withdrawal after a 6 hr but not a 3 hr exposure to 20 mM EtOH. A representative trace recorded in cell-attached patch clamp mode of a single BK channel that was (A) naïve, (B) pre-exposed to 20 mM EtOH for 3 hr and ethanol withdrawn for 24 hr, or (C) pre-exposed to 20 mM EtOH for 6 hr and ethanol withdrawn for 24 hr. Channel activity was evoked by stepping from a holding potential of -60 mV to a potential of +70 mV for the traces recorded in panels A and B or +50 mV for the traces recorded in panel C. The dwell time distribution of single channel patches are shown in the histograms below the current trace. Durations of open or closed times were measured with half-amplitude threshold analysis. Curves were fitted using a maximum-likelihood minimization routine. The open times distribution could be well fitted with a single component function while the closed time distribution was well fitted with a function of two components.

Given the pronounced difference in properties of BK channels during withdrawal from a 6 hr but not 3 hr exposure to EtOH we wanted to determine whether this phenomenon could be explained by a change in subunit composition. BK channels are comprised of 4 α subunits and auxiliary, transmembrane β subunits. Both changes in the α subunit via alternative pre-mRNA splicing or association with auxiliary β subunits can influence the biophysical properties and ethanol sensitivity of the channel (Dworetzky et al., 1994; Meera et al., 2000; Brenner et al., 2000; Behrens et al., 2000; Weiger et al., 2000; Lippiat et al., 2003; Petrik and Brenner, 2007; Feinberg-Zadek and Treistman, 2007). However, to date only particular α splice variants and β subunits have been detected in neuronal tissues. For example, in mouse brain Insertless, also referred to as ZERO, is the predominant variant expressed, accounting for more than 90% of total BK mRNA. The remaining 10% is comprised mostly of STREX mRNA (Chen et al., 2005). Similarly, β 4 is the predominant beta subunit found in neuronal tissues while β 1 and β 2 are expressed to a lesser extent (Behrens et al., 2000).

Focusing on subunit compositions that are found in neuronal tissues our lab utilized the HEK293 expression system to correlate subunit composition and ethanol sensitivity. These studies revealed that $\alpha\beta$ 1 channels are insensitive to alcohol while α or $\alpha\beta$ 4 channels are potentiated (Feinberg-Zadek and Treistman, 2007). Similarly, the α splice variant, STREX, is insensitive to alcohol while the

variants, Insertless and P27 are potentiated (Pietrzykowski et al., 2008). This led to the formation of two hypotheses. During withdrawal from 6 hr EtOH but not 3 hr EtOH treatment; (1) changes are induced in auxiliary β subunits such that there is a shift from EtOH-sensitive β 4-containing BK channels to EtOH-insensitive BK β 1 containing channels and (2) changes are induced in α splice variation such that there is a shift from an EtOH-sensitive variant, Insertless or P27, to an EtOH-insensitive variant, STREX.

Based on studies showing that $\alpha\beta$ 4 BK channels are present in the striatum (Martin et al., 2004; Martin et al., 2008) we initially favored our first hypothesis which stated that during withdrawal from a 6 hr ethanol exposure the predominant subtype of BK channel shifts from alcohol-sensitive β 4 to alcohol-insensitive β 1 containing channels. However, we abandoned this hypothesis because we found that the pharmacological properties of BK channels in rat P8 striatal neurons were inconsistent with β 4-containing channels (see Appendix A). Furthermore, immunolabeling results using an antibody which specifically binds the extracellular domain of β 4 confirmed that β 4-containing channels were not present in the membrane of striatal neurons (Appendix A).

Therefore, we wanted to determine whether withdrawal from 6 hr EtOH but not 3 hr EtOH treatment induced changes in α splice variation such that there is a shift from an EtOH-sensitive variant, Insertless or P27, to an EtOH-insensitive variant,

STREX. In support of this hypothesis previous studies demonstrated that the half-maximal activation voltage ($V_{1/2}$) of STREX is significantly less than Insertless channels (Chen et al., 2005) consistent with the shift we observe after 6 hr EtOH and 24 withdrawal (Table 1). To directly assess whether particular splice variants were present in striatal neurons we would have liked to employ immunocytochemical techniques, however there are no commercial antibodies available to detect or differentiate between specific splice variants. Additionally, should commercially available antibodies exist they would be of little use because the majority of BK splice sites are located intracellularly in the C-terminal tail (Xia et al., 2002; Krishnamoorthy et al., 2005). Thus, it would still be problematic to prove which splice variants are functionally present in the phospholipid membrane.

Therefore, we took a three-fold approach, albeit a more indirect approach, to determine whether ethanol induces changes in α splice site variation. We first determined the mRNA levels of different BK channel subunits during withdrawal from 3 and 6 hr ethanol. Secondly, we exogenously expressed various α splice site variants in HEK293 cells to describe their biophysical properties and compared these properties with those observed in striatal culture. Finally, we used pharmacological tools to discriminate between splice variant populations based on their differential regulation by secondary signaling pathways (Chen et al., 2005).

During withdrawal from 6 hr but not 3 hr EtOH STREX mRNA is upregulated.

Recent data from our lab has shown that P27, Insertless, and STREX isoforms are present in striatal neurons. Of these isoforms both P27 and Insertless are sensitive to 50 mM EtOH while STREX is alcohol insensitive (Pietrzykowski et al., 2008). Therefore, we postulated that naïve channels were comprised of alcohol sensitive variants, P27 or Insertless, and that during withdrawal from 6 hr alcohol exposure the predominance of channels shifts to the alcohol insensitive variant, STREX. To see whether STREX was upregulated after alcohol treatment specific primers to STREX were designed (see Materials and Methods). We also included primers for $\beta 1$, another BK subunit conferring alcohol insensitivity which is detected at low levels in the striatum (Martin et al., 2008) and brain (Jiang et al., 1999). Interestingly, we found that STREX was upregulated after 6 hr of withdrawal 3.11 ± 0.18 fold ($n = 6$, experiments were performed in triplicate) relative to control after 6 hr but not 3 hr 20 mM EtOH (Figure 6). Furthermore, we found that this upregulation was sustained throughout withdrawal returning to baseline after 24 hrs. In contrast, $\beta 1$ mRNA which was detected at very low levels in striatal culture did not vary significantly after 3 or 6 hr treatment (one-way Anova, $p = 0.97$).

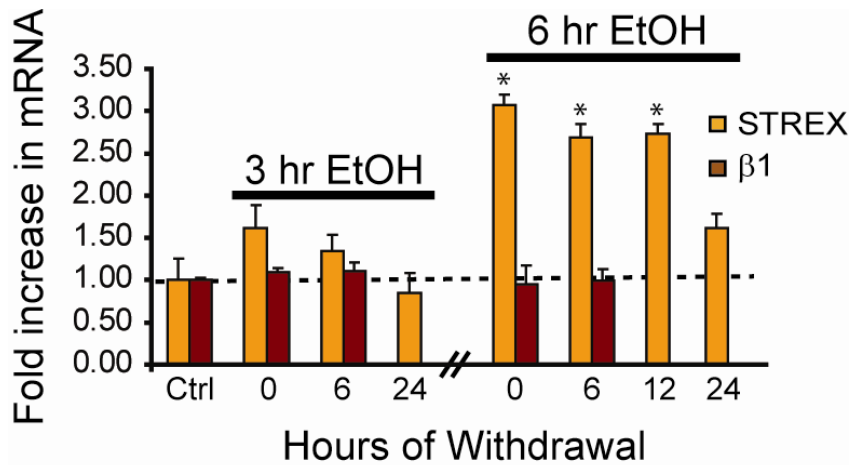

Figure 6. STREX mRNA levels during withdrawal depend on duration of EtOH exposure. (A) mRNA levels in cultured striatal neurons measured by real-time PCR with primers to the STREX α splice variant and the $\beta 1$ subunit. Six hours after initial pre-exposure to 6 hr 20 mM EtOH, STREX mRNA increased approximately three fold compared to control. Bar graphs represent the mean \pm SEM for six independent experiments performed in triplicate. Statistical significance was determined using one-way ANOVA, a single asterisk indicates $p < 0.05$.

Properties of alpha splice variants in HEK293 cells

To further demonstrate that STREX containing BK channels were present in the membrane of striatal neurons during withdrawal from a 6 hr but not 3 hr exposure to alcohol we exogenously expressed Insertless, P27, and STREX α splice variants in HEK293 cells (see Methods and Materials). We then assessed the variants biophysical properties including calcium sensitivity, activation rate, and mean open and closed times and compared these properties with those observed in striatal culture.

Macroscopic current traces were evoked from a holding potential of -60 mV to +360 mV in 20 mV increments with 1 μ M free- Ca^{2+} in the recording pipette (Figure 7A-C). G/G_{max} curves were generated as described previously (Figure 7D). After 6 hr EtOH and 24 withdrawal the half maximal activation ($V_{1/2}$) is 115.39 ± 12.84 mV ($n = 9$). Similarly, Insertless and STREX have $V_{1/2}$'s that are 126.63 ± 10.11 mV ($n = 7$) and 117.64 ± 9.95 mV ($n = 10$), respectively. However, as shown in Figure 7G/F only the STREX variant has a slower activation rate ($\tau = 12.74 \pm 2.68$ ms, $n = 3$), longer mean open ($\tau = 18.23 \pm 2.45$ ms, $n = 5$) and longer closed times ($\tau_{\text{fast}} = 55.61 \pm 12.38$ ms and $\tau_{\text{slow}} = 205.75 \pm 19.27$ ms, $n = 5$) similar to channels present during withdrawal from 6 hrs of alcohol exposure. This data is summarized in Table 1. Therefore, our data suggest the properties of channels present in the membrane after 6 hr exposure

to ethanol and 24 hr withdrawal are consistent with the alcohol-insensitive STREX variant.

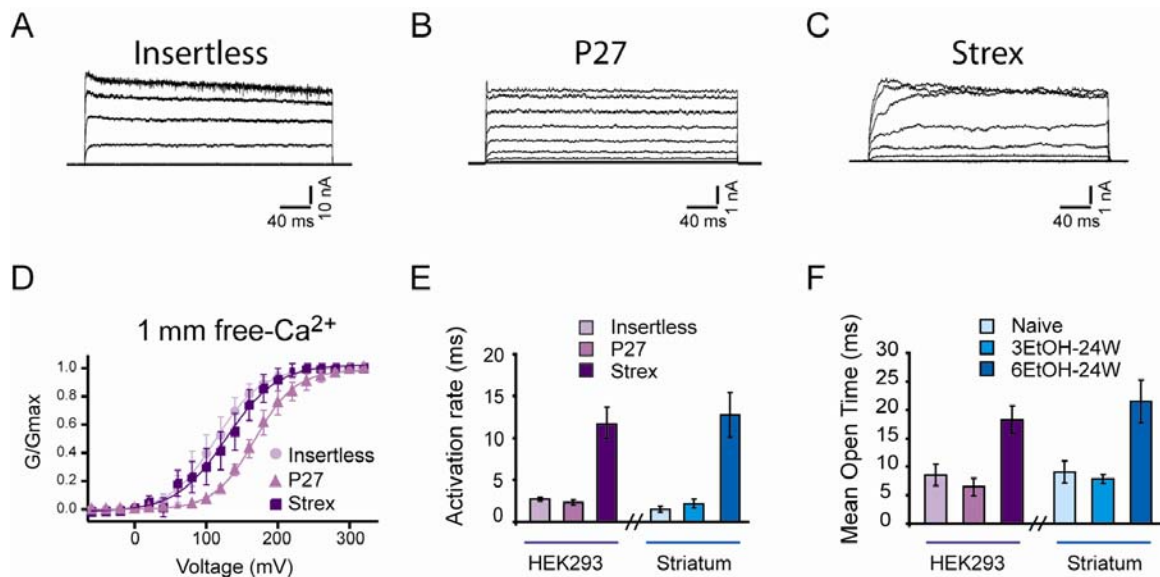

Figure 7. Biophysical properties of BK α splice variants exogenously expressed in HEK293 cells. Series of macroscopic BK (A) Insertless, (B) P27 or, (C) STREX currents evoked from a holding potential of -60 mV to +320 mV in 20 mV increments. (D) G-V relationship of Insertless (circles), P27 (triangles), and STREX (squares). Bar graph of the (E) average activation time constants taken at +120 mV from the macroscopic currents shown in panels A-C (purple) versus activation time constants for striatal BK currents (blue) exposed to 20 mM EtOH for 0, 3 or 6 hrs followed by 24 hr withdrawal (naïve, 3EtOH-24W, and 6EtOH-24W respectively) computed as previously described in Figure 4. (F) mean open time constants of single channels expressed in HEK293 cells (purple) or in striatal culture (blue) recorded in cell-attached patch clamp mode at an NPo of approximately 0.5.

		$V_{0.5}$ (mV)	Activation rate (mS)	Mean Open Time (mS)	Mean Closed Time (mS)
Striatum	<i>Naïve</i>	157.23 ± 24.77	2.70 ± 0.25	9.13 ± 1.95	τ fast = 6.71 ± 1.89, τ slow = 60.80 ± 9.32
	<i>3Et-24W</i>	146.43 ± 18.21	2.34 ± 0.33	7.86 ± 0.82	τ fast = 5.52 ± 1.14, τ slow = 53.44 ± 4.37
	<i>6Et-24W</i>	115.39 ± 12.84	19.15 ± 3.12	21.49 ± 3.76	τ fast = 70.26 ± 10.84, τ slow = 230.33 ± 31.49
Hek293	<i>P27</i>	165.12 ± 22.34	1.50 ± 0.34	6.46 ± 1.50	τ fast = 8.39 ± 2.94, τ slow = 45.21 ± 7.72
	<i>Strex</i>	117.64 ± 9.95	12.74 ± 2.68	18.23 ± 2.45	τ fast = 55.61 ± 12.38, τ slow = 205.75 ± 19.27
	<i>Insertless</i>	126.63 ± 10.11	2.17 ± 0.53	8.56 ± 1.86	τ fast = 1.92 ± 0.98, τ slow = 24.23 ± 8.78

Table 1. Summary of BK channel Properties in Striatal Culture vs. HEK293 cells.

Striatal currents are inhibited by PKA activation during withdrawal from 6 hr EtOH but not 3 hr EtOH.

Alpha splice site variants are differentially regulated by secondary signaling pathways. Therefore, to provide further evidence that STREX isoforms are present in striatal culture after 6 but not 3 hr ethanol we assessed their response to the PKA activator, 8-bromo-cyclic AMP. Previous studies had shown previously that exogenously expressed STREX is inhibited by cAMP while other isoforms such as Insertless are potentiated (Chen et al., 2005). This differential response is due the fact that there is an additional PKA site in the 59 amino acid STREX insert in the C-terminal tail.

Figure 8 shows macroscopic currents evoked from a holding potential of -60 mV to +80 mV with 1 μ M free- Ca^{2+} in the pipette after various ethanol exposures and withdrawal periods. Shown in Figure 8A and C, currents from naïve neurons or

neurons exposed to ethanol for 3 hr and withdrawn for 24 hrs were potentiated by extracellular perfusion with 250 μ m 8-bromo-cAMP (41.52 ± 8.43 and 35.94 ± 10.71 %, respectively). In sharp contrast, currents from neurons exposed to ethanol for 6 hr and ethanol withdrawn for 24 hrs were markedly inhibited (32.87 ± 15.11 %) by 8-Br-cAMP (Figure 8F) consistent with studies showing that STREX channel activity is reduced by this agonist. Interestingly, immediately following either 3 or 6 hr EtOH, application of 8-bromo-cAMP did not have a significant effect (4.02 ± 3.59 and 8.67 ± 6.20 % respectively). This may reflect a change in the phosphorylation level of BK channels induced by alcohol that occurs while the drug is still present.

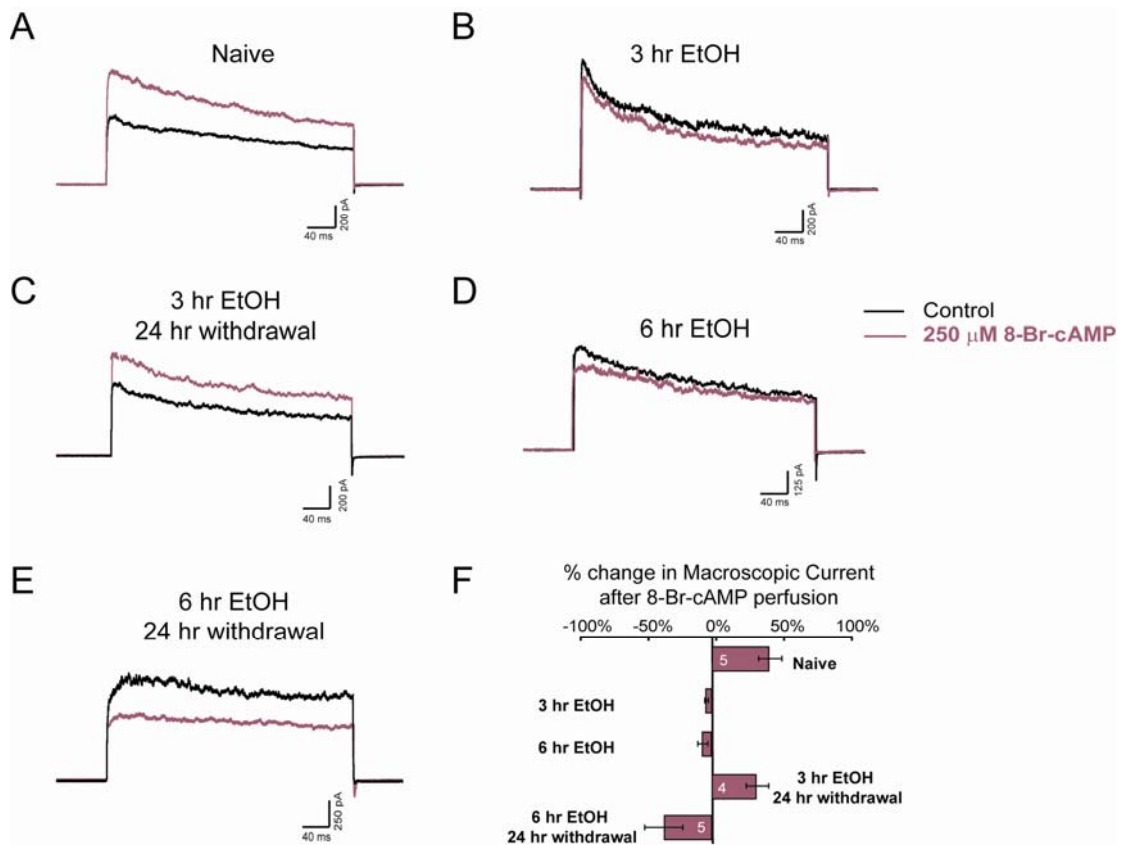

Figure 8. Effect of 8-Bromo-cAMP, a PKA activator, on striatal currents after various exposures to 20 mM EtOH. Macroscopic currents from neurons that are (A) naïve, (B) EtOH exposed for 3 hrs, (C) EtOH exposed for 3 hrs and withdrawn for 24 hrs, (D) EtOH exposed for 6 hrs, and (E) ethanol exposed for 6 hrs and withdrawn for 24 hrs are shown before and after perfusion with 250 μ M 8-Br-cAMP (black and purple, respectively). All macroscopic currents were recorded in the presence of 1 mM 4-AP, from a holding potential of -60 mV to +80 mV, with 1 μ M free- Ca^{2+} in the recording pipette. (F) Bar graph representing the percent change in macroscopic current after perfusion with 8-Br-cAMP. Numbers within the bars represent the number of patches tests. For 3 hr EtOH, n = 4 and for 6 hr EtOH, n = 5.

Recovery pattern of BK channel current density after 6 vs. 3 hr EtOH.

With both RT-PCR data suggesting that STREX mRNA is upregulated and electrophysiological evidence indicating that striatal neurons have functional channels consistent with the characteristics of exogenously expressed STREX channels after 6 but not 3 hr EtOH, we wanted to assess whether the number of channels per unit membrane had changed accordingly. Current density is commonly used as an indicator of the number of channels per unit membrane. Current density measures the amount of current flowing through a unit of membrane. Since it is known that alcohol does not change the conductance of BK channels, a change in the current flowing through a unit membrane is assumed to reflect a change in the number of channels in the membrane (Pietrzykowski et al., 2004).

Current density after 6 hr alcohol exposure exhibited a complex recovery pattern during withdrawal. Normalized current density values immediately following 20 mM EtOH exposure were first depressed (0.48 ± 0.09 , $n = 6$), but then showed an overshoot within 12 hr (2.14 ± 0.24 , $n = 9$), and did not return to baseline values for several days (Figure 9). In contrast, neither 1 hr nor 3 hr of exposure to 20 mM EtOH elicited significant changes in current density levels during withdrawal. The increase in current density during withdrawal does parallel the upregulation in STREX mRNA levels. However, there does appear to be a temporal lag between the two phenomena which may reflect the cumulative time

necessary for mRNA translation, protein trafficking, and insertion into the membrane, parameters which are currently unknown. Our lab recently speculated that the production of BK transcripts would be expected to take at least 6 hr based on the length of the BK gene and the elongation rate of polymerase II (Pietrzykowski et al., 2008) which could explain why STREX mRNA levels are 3-fold higher at the 0 withdrawal time point after 6 hr EtOH but current density levels do not peak until 12 hrs withdrawal.

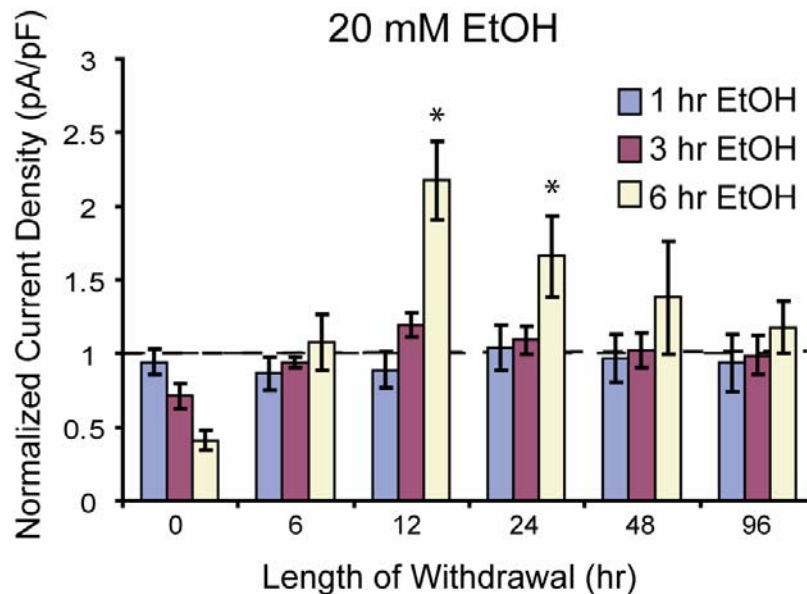

Figure 9. BK channel current density displays a complex recovery pattern during withdrawal from 6 hr EtOH but not 3 or 1 hr EtOH. Current density after 1 hr (blue), 3 hr (purple), or 6 hr (yellow) exposure to 20 mM EtOH and various withdrawal periods (n = 6 – 9). Current amplitude was obtained from the sustained component of the macroscopic potassium current. Macroscopic currents were evoked by stepping from a holding potential of -60 mV to +60 mV in Regular Locke’s solution. The asterisk denotes that $p < 0.05$ using the Student’s t-test.

Conclusion

We provide evidence here that there are temporally dependent “triggered” switches tripped by drug exposure that underlie rapid tolerance. We have also demonstrated that the machinery underlying rapid tolerance, once initiated does not require continued presence of the drug. Furthermore, we have shown that there is a swift emergence and persistence of rapid tolerance that is dependent on the duration of alcohol exposure. In addition, the mechanism underlying the long-lasting persistence of tolerance after a 6 hr EtOH exposure may be explained by an increase in an alcohol insensitive BK channel isoform called STREX.

Discussion

Evidence for EtOH induced tolerance switches

This work is an extension of studies indicating there is a relationship between EtOH exposure protocol and degree of tolerance that develops. Behavioral studies have shown the development of rapid tolerance after short alcohol exposures is dose dependent. For example, in mice and rats exposure to a single intraperitoneal (IP) dose of EtOH reduces motor impairment and hypothermic response for a second dose administered 8-24 hours after the first dose (Crabbe et al., 1979;Khanna et al., 1996). These studies also demonstrated that higher initial doses of alcohol produced the greatest degree of tolerance. Furthermore, by determining that the degree of rapid tolerance was roughly

equivalent after a single IP dose of 4 g/kg versus to two-single doses of 2 g/kg this study suggested that peak blood alcohol concentration is not as important as duration of alcohol exposure (Khanna et al., 1996). Therefore we chose to directly examine how duration of alcohol exposure influences tolerance development on a molecular level.

Numerous studies suggest the existence of alcohol triggered molecular “switches” that may contribute to the formation of behavioral rapid tolerance. For example, many studies describe changes in biochemical pathways that outlast the presence of the initiating drug of abuse and therefore qualify as drug-activated switches (Szabo and Hoffman, 1995; Pandey et al., 2001; Pandey et al., 2003; Borlikova et al., 2006). Examples of potential drug-activated switches include transcription factors such as delta fosB and CREB and secondary signaling molecules like PKA. It has also recently been discovered in flies that CREB, which is activated by PKA, mediates upregulation of *ds/o* during rapid tolerance to benzyl alcohol (Wang et al., 2007). In addition, several studies have demonstrated in neurons of the nucleus accumbens that the cAMP-PKA-CREB signaling pathway plays a role in reinforcement of drug-seeking behavior in response to cocaine, opiates, and alcohol (For review see Nestler, 1994). The general effect of drugs of abuse on the cAMP pathway suggests it plays a prominent role in drug addiction. Here, we propose that the increased activity of

transcription factors like CREB lead to the upregulation in STREX mRNA we observe in striatal culture.

In addition to studies suggesting there is a relationship between duration of drug exposure and tolerance development, there is specific evidence that 6 hr of drug exposure is critical for the development of neuroadaptations underlying addictive behaviors. For example, six hours but not one hour of daily access to self-administered cocaine results in an escalation of cocaine self-administration (Ahmed and Koob, 1999). Interestingly, since the cAMP signaling pathway is suggested to play such major role in drug addiction, it is intriguing that 6 hr but not 1 hr of alcohol exposure translocates the catalytic subunit of PKA from the Golgi area to the nucleus (Dohrman et al., 2002). Once in the nucleus PKA is able to phosphorylate the transcription factor, CREB, and mediate numerous downstream effects. The fact that the 6 vs 1 hr dichotomy appears to play a role in mediating addictive behaviors and differentially impacts the cAMP signaling pathway suggests that duration of exposure may be a critical factor influencing tolerance to all drugs of abuse. Furthermore, the duration of alcohol intake even after a single drinking session may play a significant role in the accession to addiction by influencing one's susceptibility to transition from casual drinking to compulsivity.

Other Mechanisms Underlying BK Channel Tolerance

Here, we describe a mechanism underlying rapid tolerance to alcohol involving a switch in the subunit composition of BK channels. Similar occurrences have also been demonstrated for other ion channels. Alcohol has been shown to induce alterations in the subunit composition of NMDA and GABA receptors during withdrawal. For example, chronic intermittent ethanol followed by withdrawal induces upregulation of NR2B and NR1 subunits but not NR2A subunits in both cultured mouse cortical and rat hippocampal neurons (Nagy et al., 2003; Qiang et al., 2007). Furthermore, mRNA levels of the NR1 subunit remain elevated for 48 hours post withdrawal in rat cerebral cortex (Hardy et al., 1999). Similarly, during ethanol withdrawal the expression of $\alpha 4$ subunit of GABA(A) receptors increases in cultured rat cerebellar granule cells (Follesa et al., 2001; Biggio et al., 2007).

While we postulate that a switch in the subunit composition of BK channels underlies rapid tolerance to alcohol, this does not preclude the possibility that other mechanisms do not also play a role in rapid tolerance. We know there are multiple mechanisms underlying acute alcohol tolerance of BK channels. We have shown previously that acute tolerance involves two processes; the first occurs within a few minutes of alcohol exposure and involves a reduction in alcohol-induced potentiation while the second occurs after several hours of alcohol exposure and involves a reduction in channel density (Pietrzykowski et al., 2004). In the course of this study, we found that BK channels in striatal

culture, similar to HNS channels, develop the same two components of acute tolerance.

Recently, our lab discovered that the first component of acute tolerance, reduced sensitivity to alcohol, is mediated by phosphorylation. These studies show that the development of tolerance in α Insertless channels can be blocked with a phosphatase inhibitor. Interestingly, the lack of acute tolerance observed with $\alpha\beta 4$ channels can also be reversed by applying a CaMKII inhibitor suggesting that phosphorylation plays a role in the development of acute tolerance in all BK channels regardless of subunit composition (Martin et al. 2008, *IN PRESS PNAS*).

The second component of acute tolerance, reduced channel density has been suggested to result from an increase in channel internalization into the intracellular compartment (Pietrzykowski et al., 2004). Intriguingly our lab has also found another mechanism underlying acute tolerance which involves miRNA. These studies show that within 15 minutes of alcohol exposure miR-9 levels increase in the HNS and striatum selectively degrading BK channel message (Pietrzykowski et al., 2008). Combined, these mechanisms would rapidly decrease the number of channels in the membrane. Furthermore, these studies suggest that miR-9 mediated degradation of BK channels isoforms correlates with their degree of ethanol sensitivity. For example, transcript levels

of P27, which form a channel highly sensitive to ethanol, are degraded to a greater extent than STREX transcripts, which form a channel insensitive to ethanol.

The data presented here describe yet another mechanistic level through which alcohol exerts its actions on BK channels. This mechanism involves a temporally dependent alcohol trigger that initiates the synthesis of new BK channel transcripts. The new transcripts then code for alcohol insensitive channels which are subsequently inserted into the membrane during withdrawal from the drug. It is unclear whether the four mechanisms; (1) phosphorylation, (2) internalization, (3) selective degradation of mRNA, and (4) new synthesis of transcript are linked by an alcohol-induced master controller or if the processes are completely independent. Further studies will be required to dissociate these processes and their putative role in addiction.

Why do so many mechanisms exist to counteract the effects of alcohol? It is possibly due to the inherent unpredictability of human behavior. The multiple mechanistic phases underlying tolerance allow each neuron to rapidly adapt to a given set of circumstances such as duration of alcohol exposure. Each phase likely represents an additional homeostatic change required to maintain normal firing patterns. For example, although phosphorylation quickly allows the channel to become insensitive to alcohol, alcohol at the same time decreases the

influx of calcium into the neuron (Knott et al., 2002), thereby causing BK channel activity to decrease. In this hypothetical situation, there would be increased pressure to insert BK channels into the membrane with a greater sensitivity to calcium in order to restore the balance of channels regulating neuronal firing. This dynamic interplay would continue to change throughout alcohol exposure and withdrawal requiring various mechanisms to mediate different neuroadaptations.

Acknowledgements: I would like to thank Andrew Wilson for all his support and technical advice. I would also like to thank Jose Lemos and Andrew Tapper for providing guidance throughout the course of this study. These studies were supported by funds from the NIAAA.

Appendix A

Naïve cultured striatal BK channels do not contain the auxiliary $\beta 4$ subunit.

Our lab has previously reported the pharmacological properties of BK channels in adult rat and mouse nucleus accumbens neurons and correlated these properties with the $\beta 4$ subunit (Martin et al., 2004; Martin et al., 2008). Therefore, we first hypothesized that alcohol sensitive BK $\beta 4$ -containing channels were present in naïve neurons and subsequently replaced with an ethanol insensitive channel in response to 6 hr EtOH. Utilizing HEK293 expression systems where the composition of BK channels is known, BK $\beta 4$ -containing channels have been shown to possess unique pharmacological attributes. These attributes include insensitivity to the BK channel blocker, iberiotoxin, combined with a lack of acute alcohol tolerance (Hanner et al., 1998; Meera et al., 2000; Behrens et al., 2000; Lippiat et al., 2003; Martin et al., 2008). In Figure 1A, BK channel activity is recorded at a holding potential of -60 mV, in cell-attached mode, before and after perfusion with alcohol. Initially, baseline activity is low, NPo = 0.094, and increases in activity to NPo = 0.342 upon exposure to 50 mM EtOH. However, within a few minutes of alcohol exposure channel activity returns to baseline, NPo = 0.112. A plot of the n-fold increase in channel activity after 50 mM EtOH as a function of time is shown in Figure 1B. The n-fold increase in activity peaks at 3 minutes EtOH, 7.8 ± 2.6 fold (n = 5), and returns to baseline at approximately 6 minutes (n-fold increase is 1.09 ± 0.14 , n = 5) indicating that BK

channels in naïve striatal neurons develop acute tolerance inconsistent with channels containing the $\beta 4$ -subunit.

Furthermore, macroscopic K^+ currents obtained in the presence of 1 mM 4-AP also have an iberiotoxin sensitive component. Macroscopic currents before and after perfusion with 100 nM Ibtx were elicited from a holding potential of -60 mV and stepped to a potential of +80 mV (Figure 1C). Cultured striatal neurons displayed an average of $27 \pm 7\%$ ($n = 6$) inhibition within 3 minutes Ibtx perfusion. Comparing the properties of BK channels in striatal culture to the known characteristics of exogenously expressed BK $\beta 4$ channels which are insensitive to 100 nM Ibtx we have found that the pharmacological properties of striatal channels are inconsistent with $\beta 4$ -containing channels.

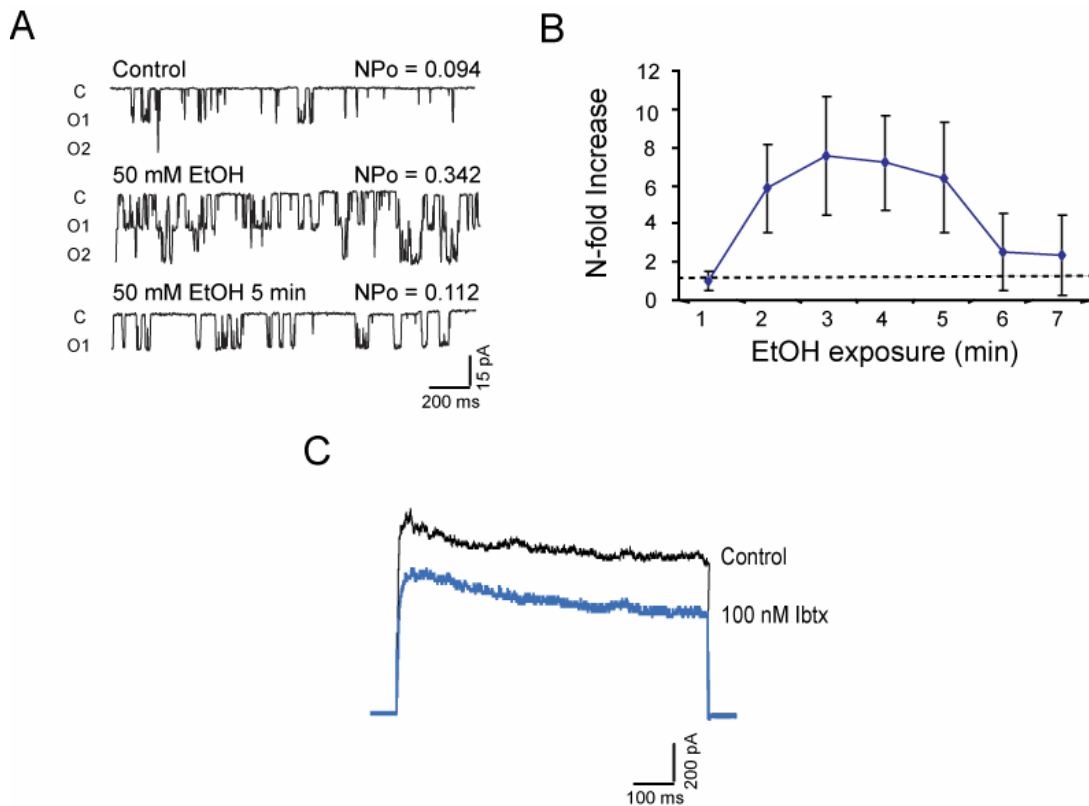

Figure 1. Naïve striatal currents are iberiotoxin sensitive and develop acute tolerance. (A) BK channel activity before and after perfusion with 50 mM EtOH. C and O represent the closed and open state respectively. (B) Plot of the n-fold increase in channel activity after 50 mM EtOH. (C) Macroscopic K⁺ current evoked, in the presence of 1 mM 4-AP from a holding potential of -60 mV to +80 mV, before (black trace) and after (blue trace) perfusion with 100 nM Iberiotoxin (Ibtx).

To confirm that $\beta 4$ -containing channels were not present in the plasma membrane, non-permeabilized striatal neurons were stained with a specific monoclonal antibody targeting the extracellular domain of the BK $\beta 4$ channel subunit. Since striatal neurons contain the neurotransmitter GABA, the cultures were then counterstained with anti-glutamate decarboxylase (GAD67), a

GABAergic neuronal marker, and DAPI, a fluorescent stain that binds DNA, in order to visualize all cells. In non-permeabilized striatal neurons $\beta 4$ staining was completely absent (Figure 2). To insure that the BK $\beta 4$ antibody specifically recognized the extracellular domain we exogenously expressed $\alpha\beta 4$ BK channels in HEK293 cells and then stained HEK293 cells that were non-permeabilized or permeabilized. Distinct channel clusters were apparent in the membrane of non-permeabilized cells, whereas diffuse staining was present when the cells were permeabilized. Similarly, when striatal neurons were permeabilized a diffuse pattern of intracellular $\beta 4$ staining was observed. This suggests that the $\beta 4$ antibody does specifically recognize the extracellular domain of the protein and that this subunit is not present in the membrane of striatal neurons. $\beta 4$, however, is present in the intracellular compartment of striatal neurons. Indeed, this is not surprising given the recent finding that $\beta 4$ subunits localize to neuronal mitochondria throughout the adult rat brain and in cultured rat neurons (Piwonska et al., 2008).

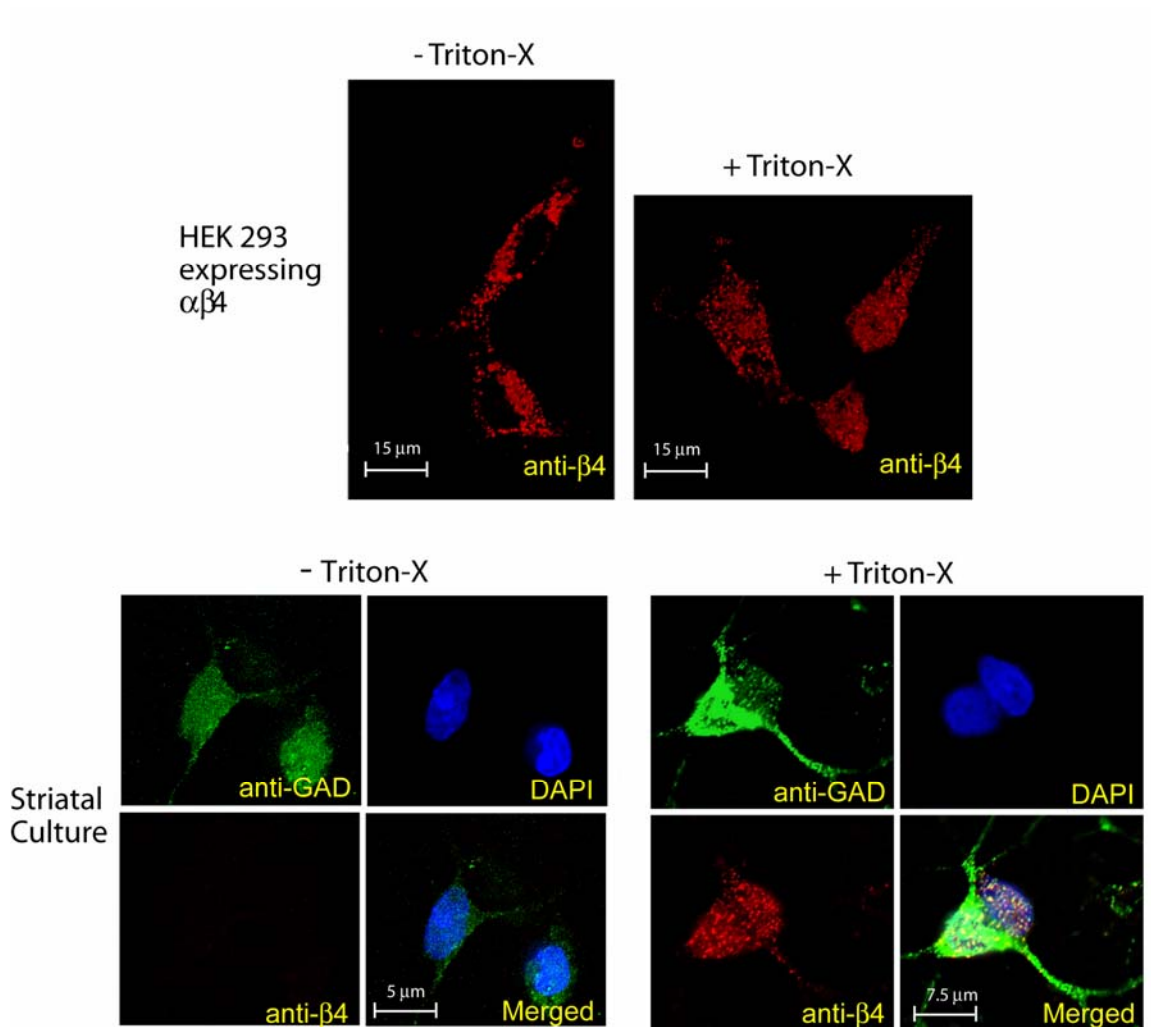

Figure 2. Immunolocalization of membrane bound and intracellular BK $\beta4$ subunits in the HEK293 and striatal neurons. In the top panels, HEK293 cells expressing $\alpha\beta4$ channels were stained with anti- $\beta4$ antibody. In both the left and right lower panels, two striatal neurons are shown that were serially immunolabeled with anti- $\beta4$, anti-GAD (a marker for GABAergic neurons), and DAPI (a nuclear stain). All panels show a 63X magnification of either permeabilized (+ Triton-X) or non-permeabilized (-Triton-X) cells.

Cumulative Discussion

The focus of my graduate work centered on the effects of acute alcohol on the BK channel, an ion channel that plays a prominent role in shaping action potentials throughout the brain. The body of this thesis comprised studies that examined (1) the dependence of acute ethanol sensitivity on subcellular location, (2) the dependence of rapid tolerance on duration of acute alcohol exposure, and (3) potential mechanisms underlying acute sensitivity and rapid tolerance.

Acute Ethanol Sensitivity is Dependent on Subcellular Location

Differential ethanol sensitivity has been documented between tissues, neighboring cells, and even within neurons. The hypothalamic-neurohypophysial system (HNS) is a particularly intriguing system to study the dependence of ethanol sensitivity on subcellular location because peptide release from the somatodendritic and nerve terminal compartments has such markedly different functions. The somatodendritic compartment secretes hormones centrally within the brain while the nerve terminals in the pituitary secrete hormones systemically into the blood. Given that ion channels largely modulate release understanding the effects of alcohol on channels within different subcellular compartment has interesting functional implications.

The data presented in this thesis examined the characteristics of BK channel subtypes in each of the three compartments of HNS neurons (dendrite, cell body,

and nerve terminal). In doing so, we discovered that both dendritic and somatic channels are insensitive to a range of physiological ethanol concentrations (20-100 mM). In contrast, BK channels in nerve terminals are highly sensitive to alcohol within the same range. The selective distribution of dendritic channels insensitive to acute EtOH may suggest that the effects of alcohol on HNS neurons mediated through BK channels have little direct impact on the integration of dendritic electrical activity. Instead, the selective distribution of ethanol sensitive BK channels to the nerve terminal compartment suggests that the effect of alcohol on HNS neurons mediated through BK channels is largely confined to the nerve terminal.

In addition to being the first to describe the properties, including ethanol sensitivity, of an ion channel in all three compartments of a neuron, I also provided a mechanism to explain these differences. I found that the properties of HNS somatodendritic and terminal BK channels were consistent with the properties of exogenously expressed $\alpha\beta 1$ and $\alpha\beta 4$ channels, respectively. Furthermore, I confirmed the regional distribution of $\alpha\beta 1$ channels in the somatodendritic compartment and $\alpha\beta 4$ channels in nerve terminals by immunolabeling adult tissue with antibodies to either the $\beta 1$ or $\beta 4$ subunit. From these studies within the HNS I suggest that regional ethanol sensitivity is modulated by β subunit composition.

While the HNS system provides a wonderful model to study the acute effects of alcohol in different subcellular compartments, I became increasingly interested in the phenomenon of tolerance. I was fascinated that acquired tolerance could contribute to an individual's increased consumption of a drug over time and ultimately lead to the compulsive drug-seeking behavior that characterizes addiction. Indeed, the HNS system is also a great model system to study tolerance, however, aspects of BK channel tolerance development had already been described (Knott et al., 2002; Pietrzykowski et al., 2004). Furthermore, channels in the somatodendritic compartment which are insensitive to alcohol are not amenable to tolerance studies. For these reasons, to further explore how alcohol affects BK channels, I chose to examine channels in the striatum, a region of the brain heavily implicated in addiction.

Persistence of Tolerance is Dependent upon Duration of Ethanol Exposure

Within the striatum, BK channels play a role in modulating action potentials and are sensitive to alcohol (Martin et al., 2004; Martin et al., 2008). However, it was previously unknown whether BK channels in this region of the brain developed tolerance. Several classes of tolerance have been described such as acute, rapid, and chronic which depend on the pattern of alcohol exposure. For example, acute tolerance refers to a reduced effect of the drug within a single drinking session (LeBlanc et al., 1975). Rapid tolerance, on the other hand, refers to a reduced response to a second dose of alcohol

administered 8-24 hrs after a first dose of alcohol (Bitran and Kalant, 1991). Lastly, chronic tolerance describes reduced effects of alcohol after multiple drinking sessions (Khanna et al., 1996). It is unknown whether the same mechanisms underlie different classes of channel tolerance or if they are completely unrelated. Therefore, one of the aims of my project was to determine whether BK channels in striatal neurons developed acute and/or rapid tolerance.

Numerous studies had suggested that the different classes of tolerance are linked to the concentration, pattern, and duration of alcohol exposure. Therefore, an additional aim of my project was to determine whether tolerance was dependent on duration of alcohol exposure. I also wanted to discover whether BK channel tolerance required continued presence of the drug, or whether once initiated by alcohol, BK channels would remain insensitive even in the absence of the drug. In order to explore these ideas I developed a striatal culture from postnatal day 8 rat pups which would allow me to precisely administer and withdraw alcohol for defined durations of time.

The results of these studies provide evidence that there are temporally dependent “triggered” switches tripped by drug exposure that underlie rapid tolerance. I have demonstrated that the machinery underlying rapid tolerance, once initiated does not require continued presence of the drug. Furthermore, I have shown that there is a swift emergence and persistence of rapid tolerance

that is dependent on the duration of alcohol exposure. In addition, the mechanism underlying long-lasting persistence of tolerance after a 6 hr EtOH exposure may be explained by an increase in an alcohol insensitive BK channel isoform called STREX. These results yield additional insight into the molecular mechanisms that contribute to the formation of drug dependence.

Caveats of Using Primary Cultures to Study Addiction

There are two major caveats that one must consider when using primary cell cultures. The first is that cultured neurons do not fully represent the normal physiological state. Neurons in culture lack the normal synaptic afferent and efferent connections that underlie learning, memory, and possibly addiction. Furthermore, neurons in primary cell lines undergo a great deal of stress during the culture process. Despite these caveats, primary cultures are a useful reductionist approach to understand how particular drugs and patterns of exposure impact molecular machinery because they allow a level of temporal precision that is unavailable *in vivo*.

The second caveat of primary cell culture is that the majority of preparations employ embryonic or early postnatal tissues due to higher success rates in obtaining proliferative cells. Therefore, another limitation of this preparation is that many neurons are developmentally regulated. Therefore, if you are examining the effects of drugs in primary culture your results may not necessarily be indicative of processes occurring in an adult or adolescent animal.

One of the obvious disconnects between BK channels in my striatal culture and BK channels in adult striatal neurons is the apparent lack of the $\beta 4$ subunit (Martin et al., 2004; Martin et al., 2008). However, this is not entirely shocking given evidence that BK channels are indeed developmentally regulated. Studies have shown that there are developmental differences in BK channel gating behavior, calcium and voltage sensitivity, and regulation by cellular signaling pathways (Blair and Dionne, 1985; Zhang et al., 2004). Furthermore, developmental shifts from charybdotoxin sensitive to charybdotoxin insensitive currents, a property shown to be unique to BK $\beta 4$ channels, have been described in rat neuroepithelium (Mienville and Barker, 1996). While I do not feel this diminishes the integrity of my work, there is a strong possibility that β -subunits modulate rapid tolerance in conjunction with changes in pre-mRNA splicing in adult animals. Furthermore, my work has concretely established that duration of drug exposure impacts the persistence of tolerance.

Addictive Behaviors are Dependent upon Drug Exposure Paradigm

The accession to compulsive drug use largely results from increased craving or drug-seeking behavior. Underlying increased craving are neuroadaptations which contribute to changes in motivational state. These changes in motivational state serve two purposes. The first motivational state serves to decrease the aversive consequences associated with drug withdrawal including physical and emotional symptoms such as anxiety and depression.

The second motivational state is an increased drive to pursue the pleasurable effects of drug use (reviewed in Nestler, 1994). Tolerance and sensitization are the two most commonly studied phenomena thought to contribute to the increased pursuit of the pleasurable effects of drugs. Tolerance and sensitization decrease or increase drug effects, respectively, in response to a constant dose. These two phenomena increase craving and lead to the escalating patterns of drug use that precede complete loss of control.

The primary focus of my thesis centers on the fact that addiction appears to relate to drug exposure paradigm. It is well established that different patterns of chronic alcohol consumption yield varying degrees of behavioral alcohol dependence. Recently, an animal model of alcohol addiction in which rats only developed compulsive drug taking when they were given alcohol *ad libitum* over a 9-month period. These studies also demonstrated that drug dependent rats exhibited compulsive drug seeking after long periods of abstinence much like humans. In contrast, animals given the free choice to consume alcohol for 2 months did not develop compulsive drug intake behaviors. Furthermore, when animals were forced to consume alcohol for 9-months they too did not develop compulsive drug-seeking behavior (Wolffgramm et al., 2000).

There is a substantial body of evidence indicating that the development of tolerance is dependent on pattern of drug exposure. For example, studies have shown that mice differentially develop tolerance to the stimulant effects of ethanol dependent on whether animals receive intermittent or continuous alcohol

exposure (Becker and Baros, 2006). Furthermore, these studies demonstrated that tolerance to stimulant effects increased with the number of chronic alcohol exposures as well as the total duration of exposure. This is similar to the results observed in mice and rats which demonstrated that tolerance to alcohol induced hypothermia and motor impairment increase with higher alcohol doses as well as duration of exposure (Crabbe et al., 1979;Khanna et al., 1996). The dependence of tolerance on pattern of drug exposure has also been described for other drugs such as cocaine and amphetamine and has also been shown to play a role in sensitization (Kokkinidis, 1984;Jones et al., 1996;Lee et al., 1998;Todtenkopf and Carlezon, Jr., 2006). This suggests that pattern of drug exposure plays a significant role in how addiction develops to all drugs of abuse.

Molecular Mechanisms Underlying Addiction

The quest to unravel the mechanisms underlying tolerance and sensitization are in the hopes that one day therapeutic interventions will be available that will effectively curtail craving and halt compulsive drug-seeking. Such potential mechanisms have been described in detail by Eric Nestler's group. Nestler's group found that in the nucleus accumbens in response to chronic cocaine, alcohol, or morphine the levels of cyclic AMP and cAMP-dependent protein kinase A increase (Terwilliger et al., 1991;Nestler, 1994). Moreover, the observed increases were specific to addictive drugs because other nonabused drugs had no effect on the cAMP-PKA system. Interestingly, the

cAMP signaling pathway also increases in striatal primary cultures in response to chronic morphine challenge suggesting that the entire mesolimbic-dopaminergic pathway is not required to mediate these effects (Hawes et al., 2006). The fact that this pathway is commonly affected by several drugs of abuse suggests that neuroadaptations in this system play a prominent role in the motivational states contributing to drug abuse.

In addition, many genetic factors have been shown to increase an individual's likelihood of developing addiction (Bosron et al., 1993; Froehlich, 1995).

Interestingly, the changes present in the cAMP-PKA pathway after drug exposure described by Nestler are also observed in naïve animals which are genetically predisposed to addictive behaviors. For example, nucleus accumbens neurons of naïve Lewis rats have much higher levels of cAMP and PKA than Fisher rats. Lewis rats also self-administer alcohol, opiates, and cocaine at much higher rates than Fisher rats (Suzuki et al., 1988; George and Goldberg, 1989) and exhibit greater place preference for these drugs, a measure of drug-seeking (Guitart et al., 1992; Kosten et al., 1994).

As described above dependency and addiction result from a mix of genetic and experiential factors. My data shed light on this interaction by providing both a potential substrate for genetic predisposition, and also an outcome of drug exposure (experience). Similar to the correlation between drug-addicted rats and genetically predisposed rats which both have increased cAMP and PKA levels,

my data suggest that a greater proportion of alcohol insensitive STREX channels in nucleus accumbens neurons, a phenomenon induced by alcohol, may represent a genetic predisposition for alcoholism. Genetic predispositions, such as the hypothetical increase in STREX channels I've described, reflect an innate tolerance to the effects of alcohol. In this way, much like acquired tolerance an individual would be likely to consume greater amounts of the drug. Interestingly, STREX channels are also upregulated in response to stress, hence the name Stress Regulated Exon (Xie and McCobb, 1998;Lai and McCobb, 2006). Stress is known to play a role in drug dependence by contributing to relapse in addicted subjects (Sinha, 2007;Clarke et al., 2008). Perhaps stress also plays a role in drug dependence by affecting an individual's propensity to crave drugs early in the addictive process. Stress may create an experience driven genetic predisposition in which the number of STREX channels present throughout the brain is higher than in non-stressed subjects.

My data have shown that even short exposures to alcohol can have relatively long-lasting consequences. An exposure as short as 6 hrs causes sustained increases in mRNA levels of STREX throughout withdrawal. These channels have been shown by exogenous expression studies to be insensitive to alcohol (Pietrzykowski et al., 2008) and potentially explain the lack of alcohol sensitivity we observe during withdrawal from a 6 hr alcohol exposure. Data from our lab has demonstrated that multiple mechanisms underlie BK channel

tolerance in the hypothalamic-neurohypophysial system and striatum. These findings are summarized in Figure 2.

The data presented here describe yet another mechanistic level through which alcohol exerts its actions on BK channels (represented in stages 4-6 of Figure 1). This mechanism involves a temporally dependent alcohol trigger that initiates the synthesis of new BK channel transcripts. The new transcripts then code for alcohol insensitive channels which are subsequently inserted into the membrane during withdrawal from the drug. It is unclear whether the four mechanisms; phosphorylation, internalization, selective degradation of mRNA, and new synthesis of transcript are linked by a common pathway or whether their effects are entirely unrelated. Further studies will be required to dissociate these processes and their putative role in addiction.

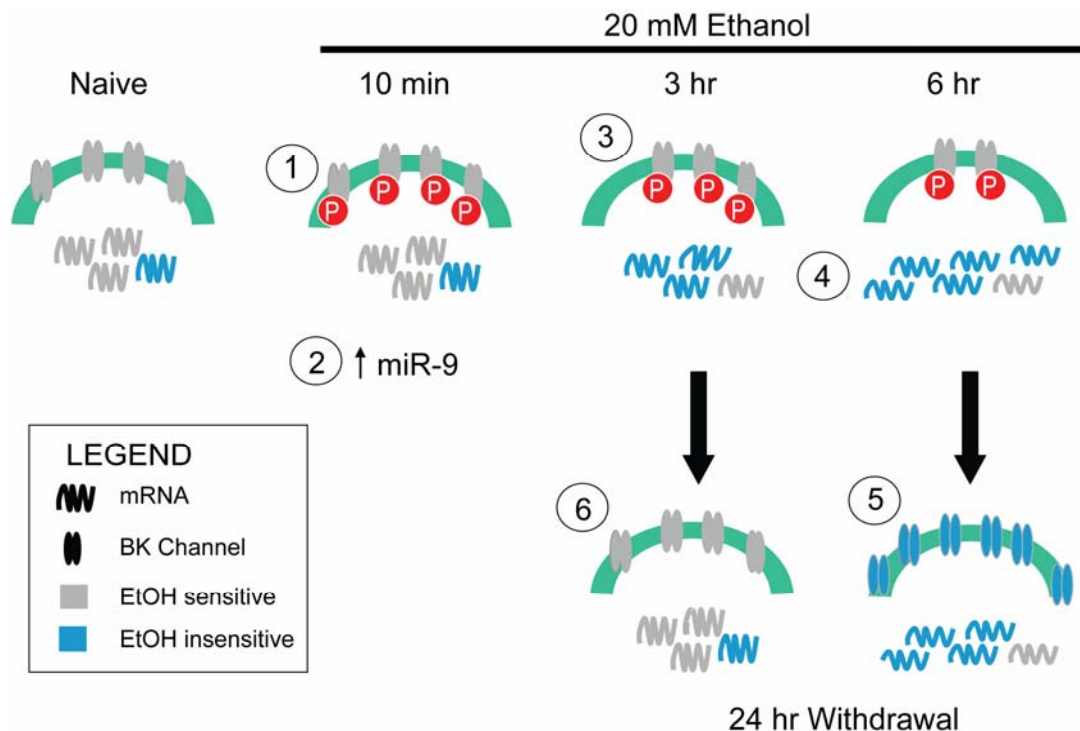

Figure 1. Mechanisms Underlying BK Channel Tolerance. (1) Acute alcohol exposure increases BK channel activity. Within ten minutes of alcohol exposure BK channels are phosphorylated and activity returns to baseline (Martin et al. 2008, In Press PNAS). (2) Within 15 minutes of alcohol exposure miR-9 levels increase selectively degrading certain BK mRNA transcripts (Pietrzykowski et al., 2008). (3) After 3 or 6 hr of alcohol BK channel current density decreases reflected as a decrease in the number of channels present in the membrane (Pietrzykowski et al., 2004) (data shown in my dissertation). (4) Levels of STREX mRNA (blue) increase and remain sustained during withdrawal dependent on duration of alcohol exposure. (5) STREX channels (blue) are inserted in the membrane during withdrawal from a 6 hr exposure and underlie the alcohol insensitive phenotype in response to additional doses of alcohol. (6) During withdrawal from a 3 hr exposure to alcohol BK channels recover and are sensitive to ethanol (grey channels).

Reference List

1. Ahmed SH, Koob GF (1999) Long-lasting increase in the set point for cocaine self-administration after escalation in rats. *Psychopharmacology (Berl)* 146: 303-312.
2. Akinshola BE, Yasuda RP, Peoples RW, Taylor RE (2003) Ethanol sensitivity of recombinant homomeric and heteromeric AMPA receptor subunits expressed in *Xenopus* oocytes. *Alcohol Clin Exp Res* 27: 1876-1883.
3. Armstrong WE (1995) Morphological and electrophysiological classification of hypothalamic supraoptic neurons. *Prog Neurobiol* 47: 291-339.
4. Bao L, Kaldany C, Holmstrand EC, Cox DH (2004) Mapping the BKCa channel's "Ca²⁺ bowl": side-chains essential for Ca²⁺ sensing. *J Gen Physiol* 123: 475-489.
5. Bao L, Rapin AM, Holmstrand EC, Cox DH (2002) Elimination of the BK(Ca) channel's high-affinity Ca(2+) sensitivity. *J Gen Physiol* 120: 173-189.
6. Becker HC, Baros AM (2006) Effect of duration and pattern of chronic ethanol exposure on tolerance to the discriminative stimulus effects of ethanol in C57BL/6J mice. *J Pharmacol Exp Ther* 319: 871-878.
7. Behrens R, Nolting A, Reimann F, Schwarz M, Waldschutz R, Pongs O (2000) hKCNMB3 and hKCNMB4, cloning and characterization of two members of the large-conductance calcium-activated potassium channel beta subunit family. *FEBS Lett* 474: 99-106.
8. Benhassine N, Berger T (2005) Homogeneous distribution of large-conductance calcium-dependent potassium channels on soma and apical dendrite of rat neocortical layer 5 pyramidal neurons. *Eur J Neurosci* 21: 914-926.
9. Benhassine N, Berger T (2008) Large-conductance calcium-dependent potassium channels prevent dendritic excitability in neocortical pyramidal neurons. *Pflugers Arch*.
10. Bichet D, Cornet V, Geib S, Carlier E, Volsen S, Hoshi T, Mori Y, De Waard M (2000) The I-II loop of the Ca²⁺ channel alpha1 subunit contains an endoplasmic reticulum retention signal antagonized by the beta subunit. *Neuron* 25: 177-190.

11. Biggio F, Gorini G, Caria S, Murru L, Sanna E, Follesa P (2007) Flumazenil selectively prevents the increase in alpha(4)-subunit gene expression and an associated change in GABA(A) receptor function induced by ethanol withdrawal. *J Neurochem* 102: 657-666.
12. Bitran M, Kalant H (1991) Learning factor in rapid tolerance to ethanol-induced motor impairment. *Pharmacol Biochem Behav* 39: 917-922.
13. Blair LA, Dionne VE (1985) Developmental acquisition of Ca²⁺-sensitivity by K⁺ channels in spinal neurones. *Nature* 315: 329-331.
14. Blichenberg A, Rehbein M, Muller R, Garner CC, Richter D, Kindler S (2001) Identification of a cis-acting dendritic targeting element in the mRNA encoding the alpha subunit of Ca²⁺/calmodulin-dependent protein kinase II. *Eur J Neurosci* 13: 1881-1888.
15. Blichenberg A, Schwanke B, Rehbein M, Garner CC, Richter D, Kindler S (1999) Identification of a cis-acting dendritic targeting element in MAP2 mRNAs. *J Neurosci* 19: 8818-8829.
16. Borghese CM, Harris RA (2007) Studies of ethanol actions on recombinant delta-containing gamma-aminobutyric acid type A receptors yield contradictory results. *Alcohol* 41: 155-162.
17. Borlikova GG, Le Merrer J, Stephens DN (2006) Previous experience of ethanol withdrawal increases withdrawal-induced c-fos expression in limbic areas, but not withdrawal-induced anxiety and prevents withdrawal-induced elevations in plasma corticosterone. *Psychopharmacology (Berl)* 185: 188-200.
18. Bosron WF, Ehrig T, Li TK (1993) Genetic factors in alcohol metabolism and alcoholism. *Semin Liver Dis* 13: 126-135.
19. Brenner R, Chen QH, Vilaythong A, Toney GM, Noebels JL, Aldrich RW (2005) BK channel beta4 subunit reduces dentate gyrus excitability and protects against temporal lobe seizures. *Nat Neurosci* 8: 1752-1759.
20. Brenner R, Jegla TJ, Wickenden A, Liu Y, Aldrich RW (2000) Cloning and functional characterization of novel large conductance calcium-activated potassium channel beta subunits, hKCNMB3 and hKCNMB4. *J Biol Chem* 275: 6453-6461.
21. Brown SM, Bentcheva-Petkova LM, Liu L, Hristov KL, Chen M, Kellett WF, Meredith AL, Aldrich RW, Nelson MT, Petkov GV (2008) Beta-adrenergic relaxation of mouse urinary bladder smooth muscle in the absence of

large-conductance Ca²⁺-activated K⁺ channel. *Am J Physiol Renal Physiol* 295: F1149-F1157.

22. Cazalis M, Dayanithi G, Nordmann JJ (1987) Hormone release from isolated nerve endings of the rat neurohypophysis. *J Physiol* 390: 55-70.
23. Chen L, Tian L, MacDonald SH, McClafferty H, Hammond MS, Huibant JM, Ruth P, Knaus HG, Shipston MJ (2005) Functionally diverse complement of large conductance calcium- and voltage-activated potassium channel (BK) alpha-subunits generated from a single site of splicing. *J Biol Chem* 280: 33599-33609.
24. Chu B, Anantharam V, Treistman SN (1995) Ethanol inhibition of recombinant heteromeric NMDA channels in the presence and absence of modulators. *J Neurochem* 65: 140-148.
25. Chu B, Dopico AM, Lemos JR, Treistman SN (1998) Ethanol potentiation of calcium-activated potassium channels reconstituted into planar lipid bilayers. *Mol Pharmacol* 54: 397-406.
26. Clarke TK, Treutlein J, Zimmermann US, Kiefer F, Skowronek MH, Rietschel M, Mann K, Schumann G (2008) HPA-axis activity in alcoholism: examples for a gene-environment interaction. *Addict Biol* 13: 1-14.
27. Cowmeadow RB, Krishnan HR, Atkinson NS (2005) The slowpoke gene is necessary for rapid ethanol tolerance in *Drosophila*. *Alcohol Clin Exp Res* 29: 1777-1786.
28. Crabbe JC, Gray DK, Young ER, Janowsky JS, Rigter H (1981) Initial sensitivity and tolerance to ethanol in mice: correlations among open field activity, hypothermia, and loss of righting reflex. *Behav Neural Biol* 33: 188-203.
29. Crabbe JC, Rigter H, Uijlen J, Strijbos C (1979) Rapid development of tolerance to the hypothermic effect of ethanol in mice. *J Pharmacol Exp Ther* 208: 128-133.
30. Crowley JJ, Treistman SN, Dopico AM (2003) Cholesterol antagonizes ethanol potentiation of human brain BKCa channels reconstituted into phospholipid bilayers. *Mol Pharmacol* 64: 365-372.
31. Crowley JJ, Treistman SN, Dopico AM (2005) Distinct structural features of phospholipids differentially determine ethanol sensitivity and basal function of BK channels. *Mol Pharmacol* 68: 4-10.

32. Csaki A, Kocsis K, Kiss J, Halasz B (2002) Localization of putative glutamatergic/aspartatergic neurons projecting to the supraoptic nucleus area of the rat hypothalamus. *Eur J Neurosci* 16: 55-68.
33. Davies DL, Kochevarov AA, Kuo ST, Kulkarni AA, Woodward JJ, King BF, Alkana RL (2005) Ethanol differentially affects ATP-gated P2X(3) and P2X(4) receptor subtypes expressed in *Xenopus* oocytes. *Neuropharmacology* 49: 243-253.
34. Dayanithi G, Widmer H, Richard P (1996) Vasopressin-induced intracellular Ca^{2+} increase in isolated rat supraoptic cells. *J Physiol* 490 (Pt 3): 713-727.
35. Dohrman DP, Chen HM, Gordon AS, Diamond I (2002) Ethanol-induced translocation of protein kinase A occurs in two phases: control by different molecular mechanisms. *Alcohol Clin Exp Res* 26: 407-415.
36. Dopico AM, Anantharam V, Treistman SN (1998) Ethanol increases the activity of Ca^{++} -dependent K^{+} (mslo) channels: functional interaction with cytosolic Ca^{++} . *J Pharmacol Exp Ther* 284: 258-268.
37. Dopico AM, Chu B, Lemos JR, Treistman SN (1999a) Alcohol modulation of calcium-activated potassium channels. *Neurochem Int* 35: 103-106.
38. Dopico AM, Lemos JR, Treistman SN (1996) Ethanol increases the activity of large conductance, Ca^{2+} -activated K^{+} channels in isolated neurohypophysial terminals. *Mol Pharmacol* 49: 40-48.
39. Dopico AM, Widmer H, Wang G, Lemos JR, Treistman SN (1999b) Rat supraoptic magnocellular neurones show distinct large conductance, Ca^{2+} -activated K^{+} channel subtypes in cell bodies versus nerve endings. *J Physiol* 519 Pt 1: 101-114.
40. Du W, Bautista JF, Yang H, Diez-Sampedro A, You SA, Wang L, Kotagal P, Luders HO, Shi J, Cui J, Richerson GB, Wang QK (2005) Calcium-sensitive potassium channelopathy in human epilepsy and paroxysmal movement disorder. *Nat Genet* 37: 733-738.
41. Dworetzky SI, Boissard CG, Lum-Ragan JT, McKay MC, Post-Munson DJ, Trojnacki JT, Chang CP, Gribkoff VK (1996) Phenotypic alteration of a human BK (hSlo) channel by hSlobeta subunit coexpression: changes in blocker sensitivity, activation/relaxation and inactivation kinetics, and protein kinase A modulation. *J Neurosci* 16: 4543-4550.

42. Dworetzky SI, Trojnacki JT, Gribkoff VK (1994) Cloning and expression of a human large-conductance calcium-activated potassium channel. *Brain Res Mol Brain Res* 27: 189-193.
43. Elkins T, Ganetzky B, Wu CF (1986) A *Drosophila* mutation that eliminates a calcium-dependent potassium current. *Proc Natl Acad Sci U S A* 83: 8415-8419.
44. Feinberg-Zadek PL, Martin G, Treistman SN (2008) BK channel subunit composition modulates molecular tolerance to ethanol. *Alcohol Clin Exp Res* 32: 1207-1216.
45. Feinberg-Zadek PL, Treistman SN (2007) Beta-subunits are important modulators of the acute response to alcohol in human BK channels. *Alcohol Clin Exp Res* 31: 737-744.
46. Fernandez-Fernandez JM, Tomas M, Vazquez E, Orio P, Latorre R, Senti M, Marrugat J, Valverde MA (2004) Gain-of-function mutation in the KCNMB1 potassium channel subunit is associated with low prevalence of diastolic hypertension. *J Clin Invest* 113: 1032-1039.
47. Fisher TE, Bourque CW (1995) Distinct omega-agatoxin-sensitive calcium currents in somata and axon terminals of rat supraoptic neurones. *J Physiol* 489 (Pt 2): 383-388.
48. Follesa P, Cagetti E, Mancuso L, Biggio F, Manca A, Maciocco E, Massa F, Desole MS, Carta M, Busonero F, Sanna E, Biggio G (2001) Increase in expression of the GABA(A) receptor alpha(4) subunit gene induced by withdrawal of, but not by long-term treatment with, benzodiazepine full or partial agonists. *Brain Res Mol Brain Res* 92: 138-148.
49. Franciolini F (1986) Patch clamp technique and biophysical study of membrane channels. *Experientia* 42: 589-594.
50. Froehlich JC (1995) Genetic factors in alcohol self-administration. *J Clin Psychiatry* 56 Suppl 7: 15-23.
51. Garcia-Calvo M, Knaus HG, McManus OB, Giangiacomo KM, Kaczorowski GJ, Garcia ML (1994) Purification and reconstitution of the high-conductance, calcium-activated potassium channel from tracheal smooth muscle. *J Biol Chem* 269: 676-682.
52. George FR, Goldberg SR (1989) Genetic approaches to the analysis of addiction processes. *Trends Pharmacol Sci* 10: 78-83.

53. Ghatta S, Nimmagadda D, Xu X, O'Rourke ST (2006) Large-conductance, calcium-activated potassium channels: structural and functional implications. *Pharmacol Ther* 110: 103-116.
54. Ghezzi A, Al Hasan YM, Larios LE, Bohm RA, Atkinson NS (2004) slo K(+) channel gene regulation mediates rapid drug tolerance. *Proc Natl Acad Sci U S A* 101: 17276-17281.
55. Giangiacomo KM, Garcia-Calvo M, Knaus HG, Mullmann TJ, Garcia ML, McManus O (1995) Functional reconstitution of the large-conductance, calcium-activated potassium channel purified from bovine aortic smooth muscle. *Biochemistry* 34: 15849-15862.
56. Grimm PR, Foutz RM, Brenner R, Sansom SC (2007) Identification and localization of BK-beta subunits in the distal nephron of the mouse kidney. *Am J Physiol Renal Physiol* 293: F350-F359.
57. Guitart X, Beitner-Johnson D, Marby DW, Kosten TA, Nestler EJ (1992) Fischer and Lewis rat strains differ in basal levels of neurofilament proteins and their regulation by chronic morphine in the mesolimbic dopamine system. *Synapse* 12: 242-253.
58. Ha TS, Jeong SY, Cho SW, Jeon H, Roh GS, Choi WS, Park CS (2000) Functional characteristics of two BKCa channel variants differentially expressed in rat brain tissues. *Eur J Biochem* 267: 910-918.
59. Hainsworth AH, Randall AD, Stefani A (2006) Whole-cell patch clamp recording of voltage-sensitive Ca²⁺ channel currents heterologous expression systems and dissociated brain neurons. *Methods Mol Biol* 312: 161-179.
60. Hamill OP, Marty A, Neher E, Sakmann B, Sigworth FJ (1981) Improved patch-clamp techniques for high-resolution current recording from cells and cell-free membrane patches. *Pflugers Arch* 391: 85-100.
61. Hanner M, Vianna-Jorge R, Kamassah A, Schmalhofer WA, Knaus HG, Kaczorowski GJ, Garcia ML (1998) The beta subunit of the high conductance calcium-activated potassium channel. Identification of residues involved in charybdotoxin binding. *J Biol Chem* 273: 16289-16296.
62. Hardy PA, Chen W, Wilce PA (1999) Chronic ethanol exposure and withdrawal influence NMDA receptor subunit and splice variant mRNA expression in the rat cerebral cortex. *Brain Res* 819: 33-39.

63. Hawes JJ, Narasimhaiah R, Picciotto MR (2006) Galanin attenuates cyclic AMP regulatory element-binding protein (CREB) phosphorylation induced by chronic morphine and naloxone challenge in Cath.a cells and primary striatal cultures. *J Neurochem* 96: 1160-1168.
64. Isaacson JS, Murphy GJ (2001) Glutamate-mediated extrasynaptic inhibition: direct coupling of NMDA receptors to Ca(2+)-activated K⁺ channels. *Neuron* 31: 1027-1034.
65. Jackson MB, Konnerth A, Augustine GJ (1991) Action potential broadening and frequency-dependent facilitation of calcium signals in pituitary nerve terminals. *Proc Natl Acad Sci U S A* 88: 380-384.
66. Jia F, Pignataro L, Harrison NL (2007) GABAA receptors in the thalamus: alpha4 subunit expression and alcohol sensitivity. *Alcohol* 41: 177-185.
67. Jiang Z, Wallner M, Meera P, Toro L (1999) Human and rodent MaxiK channel beta-subunit genes: cloning and characterization. *Genomics* 55: 57-67.
68. Jin C, Woodward JJ (2006) Effects of 8 different NR1 splice variants on the ethanol inhibition of recombinant NMDA receptors. *Alcohol Clin Exp Res* 30: 673-679.
69. Jin P, Weiger TM, Wu Y, Levitan IB (2002) Phosphorylation-dependent functional coupling of hSlo calcium-dependent potassium channel and its hbeta 4 subunit. *J Biol Chem* 277: 10014-10020.
70. Jones SR, Lee TH, Wightman RM, Ellinwood EH (1996) Effects of intermittent and continuous cocaine administration on dopamine release and uptake regulation in the striatum: in vitro voltammetric assessment. *Psychopharmacology (Berl)* 126: 331-338.
71. Kalant H (1998) Research on tolerance: what can we learn from history? *Alcohol Clin Exp Res* 22: 67-76.
72. Kalluri HS, Ticku MK (1999) Effect of ethanol on phosphorylation of the NMDAR2B subunit in mouse cortical neurons. *Brain Res Mol Brain Res* 68: 159-168.
73. Kash TL, Matthews RT, Winder DG (2008) Alcohol inhibits NR2B-containing NMDA receptors in the ventral bed nucleus of the stria terminalis. *Neuropsychopharmacology* 33: 1379-1390.

74. Khanna JM, Chau A, Shah G (1996) Characterization of the Phenomenon of rapid tolerance to ethanol. *Alcohol* 13: 621-628.
75. Kittler JT, Chen G, Honing S, Bogdanov Y, McAinsh K, Arancibia-Carcamo IL, Jovanovic JN, Pangalos MN, Haucke V, Yan Z, Moss SJ (2005) Phospho-dependent binding of the clathrin AP2 adaptor complex to GABAA receptors regulates the efficacy of inhibitory synaptic transmission. *Proc Natl Acad Sci U S A* 102: 14871-14876.
76. Knaus HG, Garcia-Calvo M, Kaczorowski GJ, Garcia ML (1994) Subunit composition of the high conductance calcium-activated potassium channel from smooth muscle, a representative of the mSlo and slowpoke family of potassium channels. *J Biol Chem* 269: 3921-3924.
77. Knott TK, Dayanithi G, Coccia V, Custer EE, Lemos JR, Treistman SN (2000) Tolerance to acute ethanol inhibition of peptide hormone release in the isolated neurohypophysis. *Alcohol Clin Exp Res* 24: 1077-1083.
78. Knott TK, Dopico AM, Dayanithi G, Lemos J, Treistman SN (2002) Integrated channel plasticity contributes to alcohol tolerance in neurohypophysial terminals. *Mol Pharmacol* 62: 135-142.
79. Kokkinidis L (1984) Effects of chronic intermittent and continuous amphetamine administration on acoustic startle. *Pharmacol Biochem Behav* 20: 367-371.
80. Korpi ER, Debus F, Linden AM, Malecot C, Leppa E, Vekovischeva O, Rabe H, Bohme I, Aller MI, Wisden W, Luddens H (2007) Does ethanol act preferentially via selected brain GABAA receptor subtypes? the current evidence is ambiguous. *Alcohol* 41: 163-176.
81. Kosten TA, Miserendino MJ, Chi S, Nestler EJ (1994) Fischer and Lewis rat strains show differential cocaine effects in conditioned place preference and behavioral sensitization but not in locomotor activity or conditioned taste aversion. *J Pharmacol Exp Ther* 269: 137-144.
82. Krishnamoorthy G, Shi J, Sept D, Cui J (2005) The NH2 terminus of RCK1 domain regulates Ca²⁺-dependent BK(Ca) channel gating. *J Gen Physiol* 126: 227-241.
83. Kurachi Y, Ishii M (2004) Cell signal control of the G protein-gated potassium channel and its subcellular localization. *J Physiol* 554: 285-294.

84. Lai GJ, McCobb DP (2006) Regulation of alternative splicing of Slo K⁺ channels in adrenal and pituitary during the stress-hyporesponsive period of rat development. *Endocrinology* 147: 3961-3967.
85. Lambert RC, Dayanithi G, Moos FC, Richard P (1994) A rise in the intracellular Ca²⁺ concentration of isolated rat supraoptic cells in response to oxytocin. *J Physiol* 478 (Pt 2): 275-287.
86. LeBlanc AE, Kalant H, Gibbins RJ (1975) Acute tolerance to ethanol in the rat. *Psychopharmacologia* 41: 43-46.
87. Lee TH, Gee KR, Ellinwood EH, Seidler FJ (1998) Altered cocaine potency in the nucleus accumbens following 7-day withdrawal from intermittent but not continuous treatment: voltammetric assessment of dopamine uptake in the rat. *Psychopharmacology (Berl)* 137: 303-310.
88. Leveque JC, Macias W, Rajadhyaksha A, Carlson RR, Barczak A, Kang S, Li XM, Coyle JT, Haganir RL, Heckers S, Konradi C (2000) Intracellular modulation of NMDA receptor function by antipsychotic drugs. *J Neurosci* 20: 4011-4020.
89. Li DP, Pan YZ, Pan HL (2001) Acetylcholine attenuates synaptic GABA release to supraoptic neurons through presynaptic nicotinic receptors. *Brain Res* 920: 151-158.
90. Lippiat JD, Standen NB, Harrow ID, Phillips SC, Davies NW (2003) Properties of BK(Ca) channels formed by bicistronic expression of hSloalpha and beta1-4 subunits in HEK293 cells. *J Membr Biol* 192: 141-148.
91. Liu J, Asuncion-Chin M, Liu P, Dopico AM (2006) CaM kinase II phosphorylation of slo Thr107 regulates activity and ethanol responses of BK channels. *Nat Neurosci* 9: 41-49.
92. Liu P, Xi Q, Ahmed A, Jaggar JH, Dopico AM (2004) Essential role for smooth muscle BK channels in alcohol-induced cerebrovascular constriction. *Proc Natl Acad Sci U S A* 101: 18217-18222.
93. Ludwig M, Bull PM, Tobin VA, Sabatier N, Landgraf R, Dayanithi G, Leng G (2005) Regulation of activity-dependent dendritic vasopressin release from rat supraoptic neurones. *J Physiol* 564: 515-522.
94. MacKinnon R, Miller C (1988) Mechanism of charybdotoxin block of the high-conductance, Ca²⁺-activated K⁺ channel. *J Gen Physiol* 91: 335-349.

95. Madeira MD, Sousa N, Lieberman AR, Paula-Barbosa MM (1993) Effects of chronic alcohol consumption and of dehydration on the supraoptic nucleus of adult male and female rats. *Neuroscience* 56: 657-672.
96. Marrion NV, Tavalin SJ (1998) Selective activation of Ca²⁺-activated K⁺ channels by co-localized Ca²⁺ channels in hippocampal neurons. *Nature* 395: 900-905.
97. Martin G, Puig S, Pietrzykowski A, Zadek P, Emery P, Treistman S (2004) Somatic localization of a specific large-conductance calcium-activated potassium channel subtype controls compartmentalized ethanol sensitivity in the nucleus accumbens. *J Neurosci* 24: 6563-6572.
98. Martin GE, Hendrickson LM, Penta KL, Friesen RM, Pietrzykowski AZ, Tapper AR, Treistman SN (2008) Identification of a BK channel auxiliary protein controlling molecular and behavioral tolerance to alcohol. *Proc Natl Acad Sci U S A*.
99. Matthews EA, Weible AP, Shah S, Disterhoft JF (2008) The BK-mediated fAHP is modulated by learning a hippocampus-dependent task. *Proc Natl Acad Sci U S A* 105: 15154-15159.
100. McKay BE, McRory JE, Molineux ML, Hamid J, Snutch TP, Zamponi GW, Turner RW (2006) Ca_v3 T-type calcium channel isoforms differentially distribute to somatic and dendritic compartments in rat central neurons. *Eur J Neurosci* 24: 2581-2594.
101. McManus OB (1991) Calcium-activated potassium channels: regulation by calcium. *J Bioenerg Biomembr* 23: 537-560.
102. Meera P, Wallner M, Toro L (2000) A neuronal beta subunit (KCNMB4) makes the large conductance, voltage- and Ca²⁺-activated K⁺ channel resistant to charybdotoxin and iberiotoxin. *Proc Natl Acad Sci U S A* 97: 5562-5567.
103. Meredith GE, Agolia R, Arts MP, Groenewegen HJ, Zahm DS (1992) Morphological differences between projection neurons of the core and shell in the nucleus accumbens of the rat. *Neuroscience* 50: 149-162.
104. Meredith GE, Ypma P, Zahm DS (1995) Effects of dopamine depletion on the morphology of medium spiny neurons in the shell and core of the rat nucleus accumbens. *J Neurosci* 15: 3808-3820.

105. Mienville JM, Barker JL (1996) Immature properties of large-conductance calcium-activated potassium channels in rat neuroepithelium. *Pflugers Arch* 431: 763-770.
106. Mody I, Glykys J, Wei W (2007) A new meaning for "Gin & Tonic": tonic inhibition as the target for ethanol action in the brain. *Alcohol* 41: 145-153.
107. Mohr E, Richter D (2004) Subcellular vasopressin mRNA trafficking and local translation in dendrites. *J Neuroendocrinol* 16: 333-339.
108. Mokdad AH, Marks JS, Stroup DF, Gerberding JL (2004) Actual causes of death in the United States, 2000. *JAMA* 291: 1238-1245.
109. Morris JF, Pow DV (1993) New anatomical insights into the inputs and outputs from hypothalamic magnocellular neurons. *Ann N Y Acad Sci* 689: 16-33.
110. Nagy J, Kolok S, Dezso P, Boros A, Szombathelyi Z (2003) Differential alterations in the expression of NMDA receptor subunits following chronic ethanol treatment in primary cultures of rat cortical and hippocampal neurones. *Neurochem Int* 42: 35-43.
111. Naini AA, Shimony E, Kozlowski E, Shaikh T, Dang W, Miller C (1996) Interaction of Ca²⁺-activated K⁺ channels with refolded charybdotoxins mutated at a central interaction residue. *Neuropharmacology* 35: 915-921.
112. Nakahara T, Hirano M, Uchimura H, Shirali S, Martin CR, Bonner AB, Preedy VR (2002) Chronic alcohol feeding and its influence on c-Fos and heat shock protein-70 gene expression in different brain regions of male and female rats. *Metabolism* 51: 1562-1568.
113. Nestler EJ (1994) Molecular neurobiology of drug addiction. *Neuropsychopharmacology* 11: 77-87.
114. Newton PM, Tully K, McMahon T, Connolly J, Dadgar J, Treistman SN, Messing RO (2005) Chronic ethanol exposure induces an N-type calcium channel splice variant with altered channel kinetics. *FEBS Lett* 579: 671-676.
115. Nie Z, Madamba SG, Siggins GR (1994) Ethanol inhibits glutamatergic neurotransmission in nucleus accumbens neurons by multiple mechanisms. *J Pharmacol Exp Ther* 271: 1566-1573.
116. Olsen RW, Hancher HJ, Meera P, Wallner M (2007) GABAA receptor subtypes: the "one glass of wine" receptors. *Alcohol* 41: 201-209.

117. Ozaita A, Martone ME, Ellisman MH, Rudy B (2002) Differential subcellular localization of the two alternatively spliced isoforms of the Kv3.1 potassium channel subunit in brain. *J Neurophysiol* 88: 394-408.
118. Pandey SC, Roy A, Mittal N (2001) Effects of chronic ethanol intake and its withdrawal on the expression and phosphorylation of the creb gene transcription factor in rat cortex. *J Pharmacol Exp Ther* 296: 857-868.
119. Pandey SC, Roy A, Zhang H (2003) The decreased phosphorylation of cyclic adenosine monophosphate (cAMP) response element binding (CREB) protein in the central amygdala acts as a molecular substrate for anxiety related to ethanol withdrawal in rats. *Alcohol Clin Exp Res* 27: 396-409.
120. Peoples RW, Stewart RR (2000) Alcohols inhibit N-methyl-D-aspartate receptors via a site exposed to the extracellular environment. *Neuropharmacology* 39: 1681-1691.
121. Petrik D, Brenner R (2007) Regulation of STREX exon large conductance, calcium-activated potassium channels by the beta4 accessory subunit. *Neuroscience* 149: 789-803.
122. Pietrzykowski AZ, Friesen RM, Martin GE, Puig SI, Nowak CL, Wynne PM, Siegelmann HT, Treistman SN (2008) Posttranscriptional regulation of BK channel splice variant stability by miR-9 underlies neuroadaptation to alcohol. *Neuron* 59: 274-287.
123. Pietrzykowski AZ, Martin GE, Puig SI, Knott TK, Lemos JR, Treistman SN (2004) Alcohol tolerance in large-conductance, calcium-activated potassium channels of CNS terminals is intrinsic and includes two components: decreased ethanol potentiation and decreased channel density. *J Neurosci* 24: 8322-8332.
124. Piwonska M, Wilczek E, Szewczyk A, Wilczynski GM (2008) Differential distribution of Ca(2+)-activated potassium channel beta4 subunit in rat brain: Immunolocalization in neuronal mitochondria. *Neuroscience* 153: 446-460.
125. Pohorecky LA (1985a) Effect of ethanol on urine output in rats. *Alcohol* 2: 659-666.
126. Pohorecky LA (1985b) Ethanol diuresis in rats: possible modifying factors. *J Pharm Pharmacol* 37: 271-273.

127. Prakriya M, Solaro CR, Lingle CJ (1996) $[Ca^{2+}]_i$ elevations detected by BK channels during Ca^{2+} influx and muscarine-mediated release of Ca^{2+} from intracellular stores in rat chromaffin cells. *J Neurosci* 16: 4344-4359.
128. Qiang M, Denny AD, Ticku MK (2007) Chronic intermittent ethanol treatment selectively alters N-methyl-D-aspartate receptor subunit surface expression in cultured cortical neurons. *Mol Pharmacol* 72: 95-102.
129. Reinhart PH, Chung S, Martin BL, Brautigan DL, Levitan IB (1991) Modulation of calcium-activated potassium channels from rat brain by protein kinase A and phosphatase 2A. *J Neurosci* 11: 1627-1635.
130. Ruela C, Sousa N, Madeira MD, Paula-Barbosa MM (1994) Stereological study of the ultrastructural changes induced by chronic alcohol consumption and dehydration in the supraoptic nucleus of the rat hypothalamus. *J Neurocytol* 23: 410-421.
131. Ruttiger L, Sausbier M, Zimmermann U, Winter H, Braig C, Engel J, Knirsch M, Arntz C, Langer P, Hirt B, Muller M, Kopschall I, Pfister M, Munkner S, Rohbock K, Pfaff I, Rusch A, Ruth P, Knipper M (2004) Deletion of the Ca^{2+} -activated potassium (BK) alpha-subunit but not the BKbeta1-subunit leads to progressive hearing loss. *Proc Natl Acad Sci U S A* 101: 12922-12927.
132. Sailer CA, Kaufmann WA, Kogler M, Chen L, Sausbier U, Ottersen OP, Ruth P, Shipston MJ, Knaus HG (2006) Immunolocalization of BK channels in hippocampal pyramidal neurons. *Eur J Neurosci* 24: 442-454.
133. Saito M, Nelson C, Salkoff L, Lingle CJ (1997) A cysteine-rich domain defined by a novel exon in a slo variant in rat adrenal chromaffin cells and PC12 cells. *J Biol Chem* 272: 11710-11717.
134. Salkoff L, Butler A, Ferreira G, Santi C, Wei A (2006) High-conductance potassium channels of the SLO family. *Nat Rev Neurosci* 7: 921-931.
135. Santhakumar V, Wallner M, Otis TS (2007) Ethanol acts directly on extrasynaptic subtypes of GABAA receptors to increase tonic inhibition. *Alcohol* 41: 211-221.
136. Sausbier M, Arntz C, Bucurenciu I, Zhao H, Zhou XB, Sausbier U, Feil S, Kamm S, Essin K, Sailer CA, Abdullah U, Krippeit-Drews P, Feil R, Hofmann F, Knaus HG, Kenyon C, Shipston MJ, Storm JF, Neuhuber W, Korth M, Schubert R, Gollasch M, Ruth P (2005) Elevated blood pressure linked to primary hyperaldosteronism and impaired vasodilation in BK channel-deficient mice. *Circulation* 112: 60-68.

137. Sausbier M, Hu H, Arntz C, Feil S, Kamm S, Adelsberger H, Sausbier U, Sailer CA, Feil R, Hofmann F, Korth M, Shipston MJ, Knaus HG, Wolfer DP, Pedroarena CM, Storm JF, Ruth P (2004) Cerebellar ataxia and Purkinje cell dysfunction caused by Ca²⁺-activated K⁺ channel deficiency. *Proc Natl Acad Sci U S A* 101: 9474-9478.
138. Schulteis G, Liu J (2006) Brain reward deficits accompany withdrawal (hangover) from acute ethanol in rats. *Alcohol* 39: 21-28.
139. Shibuki K (1984) Supraoptic neurosecretory cells: synaptic inputs from the nucleus accumbens in the rat. *Exp Brain Res* 53: 341-348.
140. Sinha R (2007) The role of stress in addiction relapse. *Curr Psychiatry Rep* 9: 388-395.
141. Smothers CT, Clayton R, Blevins T, Woodward JJ (2001) Ethanol sensitivity of recombinant human N-methyl-D-aspartate receptors. *Neurochem Int* 38: 333-340.
142. Suwaki H, Kalant H, Higuchi S, Crabbe JC, Ohkuma S, Katsura M, Yoshimura M, Stewart RC, Li TK, Weiss F (2001) Recent research on alcohol tolerance and dependence. *Alcohol Clin Exp Res* 25: 189S-196S.
143. Suzuki T, Otani K, Koike Y, Misawa M (1988) Genetic differences in preferences for morphine and codeine in Lewis and Fischer 344 inbred rat strains. *Jpn J Pharmacol* 47: 425-431.
144. Szabo G, Hoffman PL (1995) Brain-derived neurotrophic factor, neurotrophin-3 and neurotrophin-4/5 maintain functional tolerance to ethanol. *Eur J Pharmacol* 287: 35-41.
145. Terwilliger RZ, Beitner-Johnson D, Sevarino KA, Crain SM, Nestler EJ (1991) A general role for adaptations in G-proteins and the cyclic AMP system in mediating the chronic actions of morphine and cocaine on neuronal function. *Brain Res* 548: 100-110.
146. Theodosis DT (1985) Oxytocin-immunoreactive terminals synapse on oxytocin neurones in the supraoptic nucleus. *Nature* 313: 682-684.
147. Thorneloe KS, Meredith AL, Knorn AM, Aldrich RW, Nelson MT (2005) Urodynamic properties and neurotransmitter dependence of urinary bladder contractility in the BK channel deletion model of overactive bladder. *Am J Physiol Renal Physiol* 289: F604-F610.

148. Tian L, Coghill LS, McClafferty H, MacDonald SH, Antoni FA, Ruth P, Knaus HG, Shipston MJ (2004) Distinct stoichiometry of BKCa channel tetramer phosphorylation specifies channel activation and inhibition by cAMP-dependent protein kinase. *Proc Natl Acad Sci U S A* 101: 11897-11902.
149. Tian L, Duncan RR, Hammond MS, Coghill LS, Wen H, Rusinova R, Clark AG, Levitan IB, Shipston MJ (2001) Alternative splicing switches potassium channel sensitivity to protein phosphorylation. *J Biol Chem* 276: 7717-7720.
150. Todtenkopf MS, Carlezon WA, Jr. (2006) Contribution of drug doses and conditioning periods to psychomotor stimulant sensitization. *Psychopharmacology (Berl)* 185: 451-458.
151. Toro L, Wallner M, Meera P, Tanaka Y (1998) Maxi-K(Ca), a Unique Member of the Voltage-Gated K Channel Superfamily. *News Physiol Sci* 13: 112-117.
152. Varea E, Castillo-Gomez E, Gomez-Climent MA, Blasco-Ibanez JM, Crespo C, Martinez-Guijarro FJ, Nacher J (2007) PSA-NCAM expression in the human prefrontal cortex. *J Chem Neuroanat* 33: 202-209.
153. Wallner M, Meera P, Toro L (1996) Determinant for beta-subunit regulation in high-conductance voltage-activated and Ca(2+)-sensitive K⁺ channels: an additional transmembrane region at the N terminus. *Proc Natl Acad Sci U S A* 93: 14922-14927.
154. Wallner M, Meera P, Toro L (1999) Molecular basis of fast inactivation in voltage and Ca²⁺-activated K⁺ channels: a transmembrane beta-subunit homolog. *Proc Natl Acad Sci U S A* 96: 4137-4142.
155. Wang G, Dayanithi G, Kim S, Hom D, Nadasdi L, Kristipati R, Ramachandran J, Stuenkel EL, Nordmann JJ, Newcomb R, Lemos JR (1997) Role of Q-type Ca²⁺ channels in vasopressin secretion from neurohypophysial terminals of the rat. *J Physiol* 502 (Pt 2): 351-363.
156. Wang G, Dayanithi G, Newcomb R, Lemos JR (1999a) An R-type Ca(2+) current in neurohypophysial terminals preferentially regulates oxytocin secretion. *J Neurosci* 19: 9235-9241.
157. Wang G, Thorn P, Lemos JR (1992) A novel large-conductance Ca(2+)-activated potassium channel and current in nerve terminals of the rat neurohypophysis. *J Physiol* 457: 47-74.

158. Wang J, Zhou Y, Wen H, Levitan IB (1999b) Simultaneous binding of two protein kinases to a calcium-dependent potassium channel. *J Neurosci* 19: RC4.
159. Wang Y, Krishnan HR, Ghezzi A, Yin JC, Atkinson NS (2007) Drug-induced epigenetic changes produce drug tolerance. *PLoS Biol* 5: 2342-2353.
160. Wanner SG, Koch RO, Koschak A, Trieb M, Garcia ML, Kaczorowski GJ, Knaus HG (1999) High-conductance calcium-activated potassium channels in rat brain: pharmacology, distribution, and subunit composition. *Biochemistry* 38: 5392-5400.
161. Weiger TM, Holmqvist MH, Levitan IB, Clark FT, Sprague S, Huang WJ, Ge P, Wang C, Lawson D, Jurman ME, Glucksmann MA, Silos-Santiago I, DiStefano PS, Curtis R (2000) A novel nervous system beta subunit that downregulates human large conductance calcium-dependent potassium channels. *J Neurosci* 20: 3563-3570.
162. Werner ME, Zvara P, Meredith AL, Aldrich RW, Nelson MT (2005) Erectile dysfunction in mice lacking the large-conductance calcium-activated potassium (BK) channel. *J Physiol* 567: 545-556.
163. Widmer H, Lemos JR, Treistman SN (1998) Ethanol reduces the duration of single evoked spikes by a selective inhibition of voltage-gated calcium currents in acutely dissociated supraoptic neurons of the rat. *J Neuroendocrinol* 10: 399-406.
164. Wolffgramm J, Galli G, Thimm F, Heyne A (2000) Animal models of addiction: models for therapeutic strategies? *J Neural Transm* 107: 649-668.
165. Xia XM, Zeng X, Lingle CJ (2002) Multiple regulatory sites in large-conductance calcium-activated potassium channels. *Nature* 418: 880-884.
166. Xie J, McCobb DP (1998) Control of alternative splicing of potassium channels by stress hormones. *Science* 280: 443-446.
167. Zhang Y, Joiner WJ, Bhattacharjee A, Rassendren F, Magoski NS, Kaczmarek LK (2004) The appearance of a protein kinase A-regulated splice isoform of slo is associated with the maturation of neurons that control reproductive behavior. *J Biol Chem* 279: 52324-52330.

168. Zhou XB, Arntz C, Kamm S, Motejlek K, Sausbier U, Wang GX, Ruth P, Korth M (2001) A molecular switch for specific stimulation of the BKCa channel by cGMP and cAMP kinase. *J Biol Chem* 276: 43239-43245.
169. Zhou Y, Wang J, Wen H, Kuchеровsky O, Levitan IB (2002) Modulation of *Drosophila* slowpoke calcium-dependent potassium channel activity by bound protein kinase a catalytic subunit. *J Neurosci* 22: 3855-3863.